

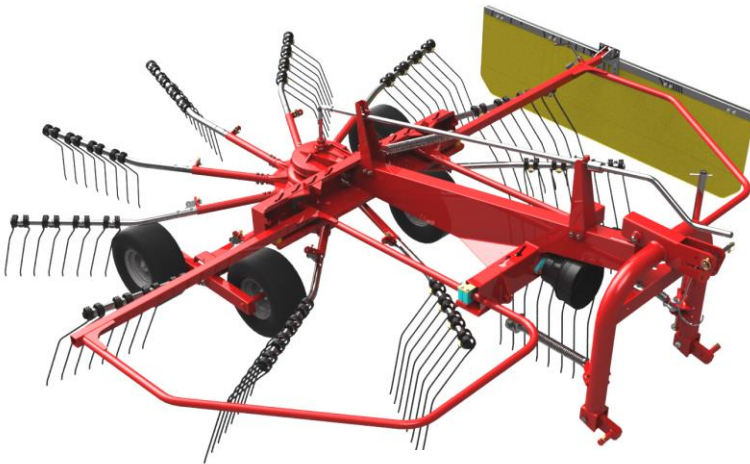

# WINDROW ROTARY RAKE

## RR 420 EVO



**RR - EVO**  
(MOUNTED)

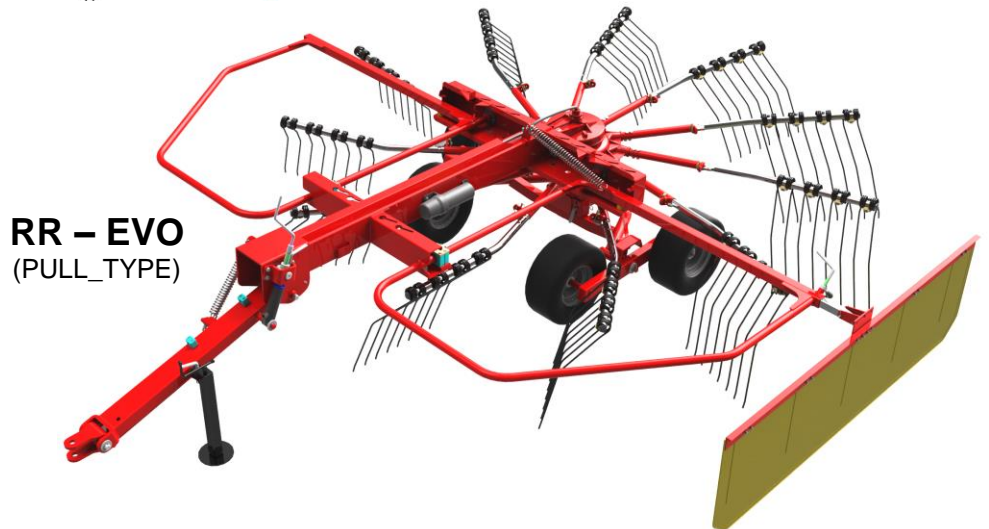

**RR - EVO**  
(PULL\_TYPE)

# OPERATOR'S MANUAL

rev.5b - 5/17





## TABLE OF CONTENTS

A.	INTRODUCTION	5
A.1	ABOUT THE MANUAL	5
A.2	IDENTIFICATION	5
A.3	MAIN COMPONENTS AND TECHNICAL DATA	5
A.4	WARRANTY	6
B.	SAFETY	8
B.1	GENERAL RULES	8
B.2	TRANSPORTATION, INSTALLATION AND MOVEMENT	8
B.3	INTENDED USE AND WARNING OF EMPLOY	10
B.4	REASONABLY FORESEEABLE MISUSE AND LIMIT OF EMPLOY	12
B.5	RESPONSABILITY OF THE OPERATOR	13
B.6	SAFETY LABELS	13
B.7	NOISE LEVELS	14
B.8	RESIDUAL RISKS	14
C.	INSTALLATION	15
C.1	PRELIMINARY INFORMATIONS	15
C.2	INSTALLATION TO TRACTOR	15
C.3	INSTALLATION AND ADJUSTMENT OF CARDAN SHAFT	16
C.4	HYDRAULIC HOSES	17
C.5	REMOVAL	17
C.6	STORING THE RAKE	17
D.	OPERATION AND USE	18
D.1	WORKING CONFIGURATION	18
D.2	WORKING PROCESS	19
D.3	ADAPTATION TO THE PARALLEL WINDROW ROTARY RAKE TO THE GROUND	19
D.4	ADAPTATION OF THE WINDROW TINE DISTANCE FROM THE GROUND	20
D.5	ADJUSTMENT OF THE HYDRAULIC CYLINDER MOVING	21
D.6	ADJUSTMENT OF THE SIDE DEFLECTOR DISTANCE FROM THE GROUND	21
D.7	ADJUSTMENT OF THE SIDE DEFLECTOR RANGE	22
D.8	CHANGE OF DIRECTION (U-TURN)	22
D.9	END OF THE WORK	22
E.	MAINTENANCE	23
E.1	WARNING DURING MAINTENANCE	23
E.2	MAINTENANCE TASKS	23
E.3	REPLACEMENT OF THE WINDOW TINES	22
E.4	TROUBLESHOOTING	22
E.5	MACHINE DEMOLITION: DISPOSAL OF MATERIALS	24
	ASSEMBLY INSTRUCTIONS	27
	PULL-TYPE ASSEMBLY	28
	MOUNTED ASSEMBLY	43
	SERVICE PARTS - MOUNTED TYPE	60
	SERVICE PARTS – PULL-TYPE	72
	SPARE PARTS FORM	93





## A. INTRODUCTION

### A.1 About the manual

The H&S firm ("Manufacturer") designed and created the device in accordance with the associated safety standards to ensure the safety of personnel and the entire operating system.

Each rake is supplied with a copy of this manual which the operator must read in full before using the equipment. The manual contains all information relating to transportation, use and maintenance of the equipment, as well as safety instructions.

Poor knowledge of the operating system can lead to accidents and therefore damage to the equipment. Although the Manufacturer provides the Customer with all information relating to the rake operation, use and maintenance, the Customer is still expected to read this manual and take note of all the instructions herein.

The manual provides all the necessary instructions on how to ensure optimal working order and safety.

The manual was drawn up according to the current technical and structural characteristics of three models of rake and does not cover previous similar models. The Manufacturer therefore reserves the right to modify models in production in the interest of improvement or due to any new legislation (Machinery Directive), without being obliged to modify previous models.

This manual is integral to the rake and must therefore be kept intact, clean and in good condition. It should also be in a container, either on the frame of the rake or in the tractor cabin, where it can be easily accessed for consultation.

The manual must be kept in its container if the rake is taken out of service. Ask the Manufacturer for a duplicate copy if the original manual is lost.

Please contact the H&S Dealer for any clarifications relating to the instructions in this manual.

Symbols used in this manual:



### HAZARD

Indicates an imminently hazardous situation that, if not avoided, will result in death or serious injury.



### WARNING

Indicates a potentially hazardous situation that, if not avoided, could result in death or serious injury. It is also used to alert against unsafe practices.



### CAUTION

Indicates a potentially hazardous situation that, if not avoided, may result in minor or moderate injury. It is also used as a reminder of good safety practices.

Type: XXXXXXXX Model

Serial N. XXXXXXXX-XX

MFG: 2015 DEL: 2015



### IMPORTANT

The operator must take the respective information into account.

**Note** indicates that the information referred to can facilitate the operator work.

### A.2 Identification

An identification plate is applied to each machine:

You must have this information at hand when requesting assistance and spare parts.

### IMPORTANT

It is strictly forbidden to alter and/or eliminate the data on the serial plate. The operator must check the legibility of the data on a regular basis and inform the Manufacturer if it becomes in any way illegible. The Manufacturer will then replace the old plate with a new one bearing the same data.

### A.3 Main components and technical data

1. Three-point hitch
2. Cardan shaft attachment
3. Steering damper spring
4. Lateral protection screens
5. Working rotate unit
6. Tine-holder arm
7. Lateral deflector
8. Wheels
9. Windrowing tines
10. Arm-holder supports
11. Frame
12. Bearing foot
13. Adjusting lever of tine height
14. Tow hitch

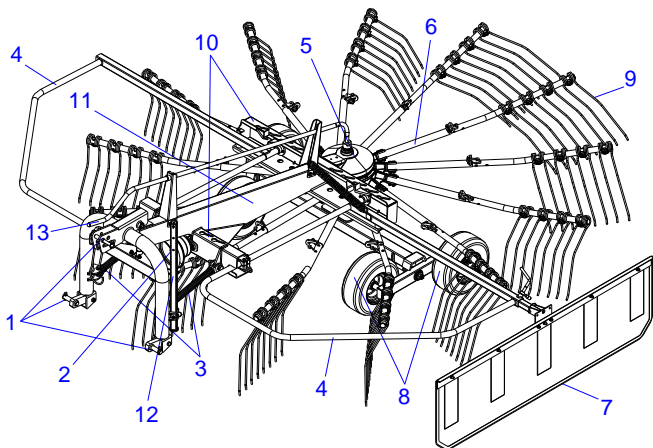

MOUNTED TYPE

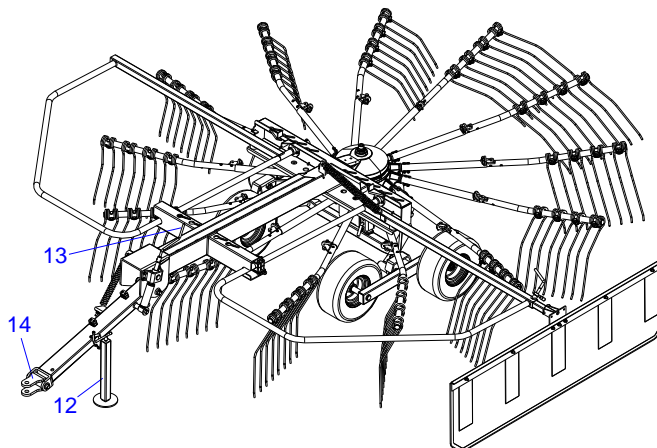

PULL-TYPE

TECHNICAL FEATURES		RR 420 EVO MOUNTED	RR 420 EVO PULL-TYPE
Transport width	cm.	170	170
Working width with windrow	cm.	400	400
Windrow width	cm.	80	80
Tine-holder arms	nr.	11	11
Double tines	nr.	4 / 44	4 / 44
PTO	rpm	540	540
Tractor power	Hp	30	30
Tractor speed in working phase	km/h	15	15
Cardan shaft + torque limiter	Nm	600	600
Tires - Ballon 18" - 8.50"x8"	nr.	4	4
Weight	kg	625	600

#### A4 Warranty

**H&S** (called Manufacturer) guarantees every component of the windrow rotary rake is without defects, as they are tested before delivering the machine to the Customer. **The warranty has a 1 year validity starting from the date indicated on the tax delivery document, except different agreements underwritten with the Customer.**

However, upon receipt of the windrow rotary rake, they must verify that it is intact and complete in its every part. Any claims must reach the Manufacturer in writing within 8 days from receipt of the equipment.

H&S commits to replace the components that, for manufacturing or material defects, cause a fault in the operation at its establishment, within the warranty period and free of charge. Should it not be possible such replacement at its own premises, the Manufacturer commits to sending the faulty pieces at the Customer's premises.

With regard to these replacements, H&S does not waive the warranty period during the time which the windrow rotary rake remains still, or recognises any damage or indemnity to the Customer, for direct and indirect expenses or damages. Should the intervention of our technician be required, the relative labour, travel and overnight expenses will be fully charged to the Customer. Only the Manufacturer or its technicians can ascertain the fault.

**However, it must be taken into consideration that:**

- the faulty pieces remain the property of the Manufacturer;
- should replacement be carried out at the Customer's establishment, the faulty pieces must be returned and, therefore, sent to the Manufacturer, for subjecting to technical review, integrates without tampering, without tampering and **carriage paid**;

- in case faulty pieces cannot be returned to the Manufacturer within 30 days, from date of receiving the new ones and with the methods described in the previous point, the Manufacturer reserves the right to sending an invoice for the new delivered pieces.

**The warranty is not recognised:**

- during transport as the windrow rotary rake travels under Customer responsibility;
- when faults derive from improper or incorrect use of the windrow rotary rake or operator negligence;
- when faults are caused by normal wear, even with the windrow rotary rake not working;
- in case of late signalling of the manufacturing defects;
- in case of accidents or fortuitous cases of force majeure.

**The warranty becomes void in case:**

- the windrow rotary rake is used by non-appropriately trained personnel;
- the indications and/or regulations in these instructions have not been followed or complied with;
- the envisioned maintenance interventions have not been carried out;
- the Customer makes modifications to the windrow rotary rake without the written authorisation of the Manufacturer or tampers with the components;
- non-original spare parts are used or non-conform to those recommended by the Manufacturer.

However, the warranty period recognised for the windrow rotary rake is not valid for all components that are not produced by the Manufacturer and for which that reported in the relative purchase notes remains valid.

**IMPORTANT**

The Manufacturer does not guarantee conformity of the windrow rotary rake with the legal dispositions in force and, in particular, with those relating to accident-prevention and pollution in the non-E.U. Countries. The adaptation of the windrow rotary rake to the respective regulations will be the full responsibility and at the expense of the Customer. The Manufacturer is relieved from every responsibility, if the inobservance of these regulations raises controversies or causes any damage.

## B. SAFETY

### B.1 General rules

This manual describes the safety regulations to be followed when using the rake. As most work-related accidents occur due to non-compliance with the most basic of safety regulations, **it is mandatory** to read this manual before using the rake and to follow all the instructions.

In its use the equipment must be used by qualified adult personnel trained. **The Manufacturer cannot be held liable for accidents due to the operator's negligence and/or non-compliance with the safety instructions. In this case the Manufacturer assumes no responsibility and the warranty is forfeited.**

### B.2 Transportation, Installation and Movement

**Transport** (delivery): This operation is carried out by a vehicle with dimensions and weight suitable to the equipment. Load and unload operations from the vehicle can be done either by using a lifting device or by using appropriate ramps hooked to the vehicle:

- In the first case, the vehicle must have suitable features and slings to support the windrow rotary rake. Trained personnel will carry out the operation by holding the equipment in the indicated sections on the frame, set for this purpose. - **Note:** *to protect the integrity of the frame, it is recommended to not handle the windrow rotary rake with metal chains, but to use approved belts. However, an adhesive label has been applied to the points where it should be fixed or sling should pass through, containing a hook (as in figure), to highlight its use.*



- In the second case instead, by using a forklift truck or a tractor, the equipment is pushed in reverse to the vehicle loading surface.

In both cases, the equipment must be in compliance with the transport configuration (forward described) and, once placed on the vehicle, it must be fastened to its structure and provided with all the safety devices required for transportation.



## HAZARD

**Load and unload operations always entail dangerous situations, thus requiring the operators in charge to be very careful.**

However, it is recommended to always observe the following **precautions**:

- operations must always be carried out on an even surface and by respecting a safe distance from escarpment or ditch borders;
- ensure ramps are robust enough to support the windrow rotary rake, that are firmly fastened to the vehicle structure, parallel between them and perpendicular to the vehicle side;
- ensure ramps are clean, without any trace of oil, grease or ice;
- do not change direction during ascent/descent operations of the windrow rotary rake on ramps. Should the path must be changed, take back the equipment and proceed with its correction.

*For long distances, the equipment is transported dismounted inside a wooden box. Once the components are delivered, detailed instructions allow the Customer to easily and rapidly assemble the windrow rotary rake. So in the event the equipment is sold or transferred to another user, follow the instructions in the reverse order to dismount it.*

**Installation:** the **pull-type** model windrow rotary rake can be installed on any agricultural tractor, provided with a tow hitch and rear auxiliary hydraulic couplings; whereas the **mounted** one can be installed on any tractor provided with rear universal 3-point hitch and of coupling and hydraulic lift.

### IMPORTANT

The tractor must also, by law, be fitted with a protective Roll-bar or ROPS or FOPS cabin. **It is strictly forbidden to install the equipment on a tractor without the required protection equipment.**

However, before installing, the Customer must consult the relative use and maintenance manual to ensure the tractor has the necessary requisites for the windrow rotary rake use and function and/or is equipped with ballasts to eliminate any unbalances that might cause its overturn.

For instructions relating to the installation of the windrow rotary rake and any hydraulic connections, consult the relative paragraphs. For information relating to the cardan shaft, follow those attached to the accessory.

**Moving on road:** **pull-type** windrow rotary rake can be moved on road only if it is connected to the towing hook; whereas the **mounted** one must be lifted by using the hydraulic lift, until the lowest section results at 40/50 cm from the ground. In both cases, the following obligations must be complied with:

- **rear overall dimensions:** the operator must apply special panels to the windrow rotary rake (**either if it is mounted or pull-type**), to highlight the tractor rear dimensions. They must be applied on the three visible sides and be retro-reflecting and fluorescent with yellow and red stripes, and be approved. Moreover, transversal dimensions of the equipment must never be higher than the tractor's shape and therefore, it must always assume the set **transport configuration** (with side protection screens closed and teeth-holder bar removed) as indicated in the **fig.4**.
- **signaling devices:** the tractor must be mandatory provided with the light flashing device (yellow or orange) always operating. Moreover, visual signal and lighting devices of tractor must be repeated or moved if dimensions of the windrow rotary rake do not

allow visibility. In this case it will be necessary to install on the equipment rear part a special light bar;

- **weight:** the total mass of the machinery (tractor with windrow rotary rake) must not exceed 30% above the normal mass of the tractor, indicated on its vehicle registration. The tractor must always move at moderate speed, especially on slopes, because the rear weight may cause loss of control;
- **laws:** however, it is recommended to know and comply with laws on road circulation in your Country.

During the machinery on-road moving (tractor with windrow rotary rake), the operator in the cabin must observe the following precautions:

- must not take passengers on the tractor;
- must not transport persons or animals on the equipment;
- PTO must always be disengaged.

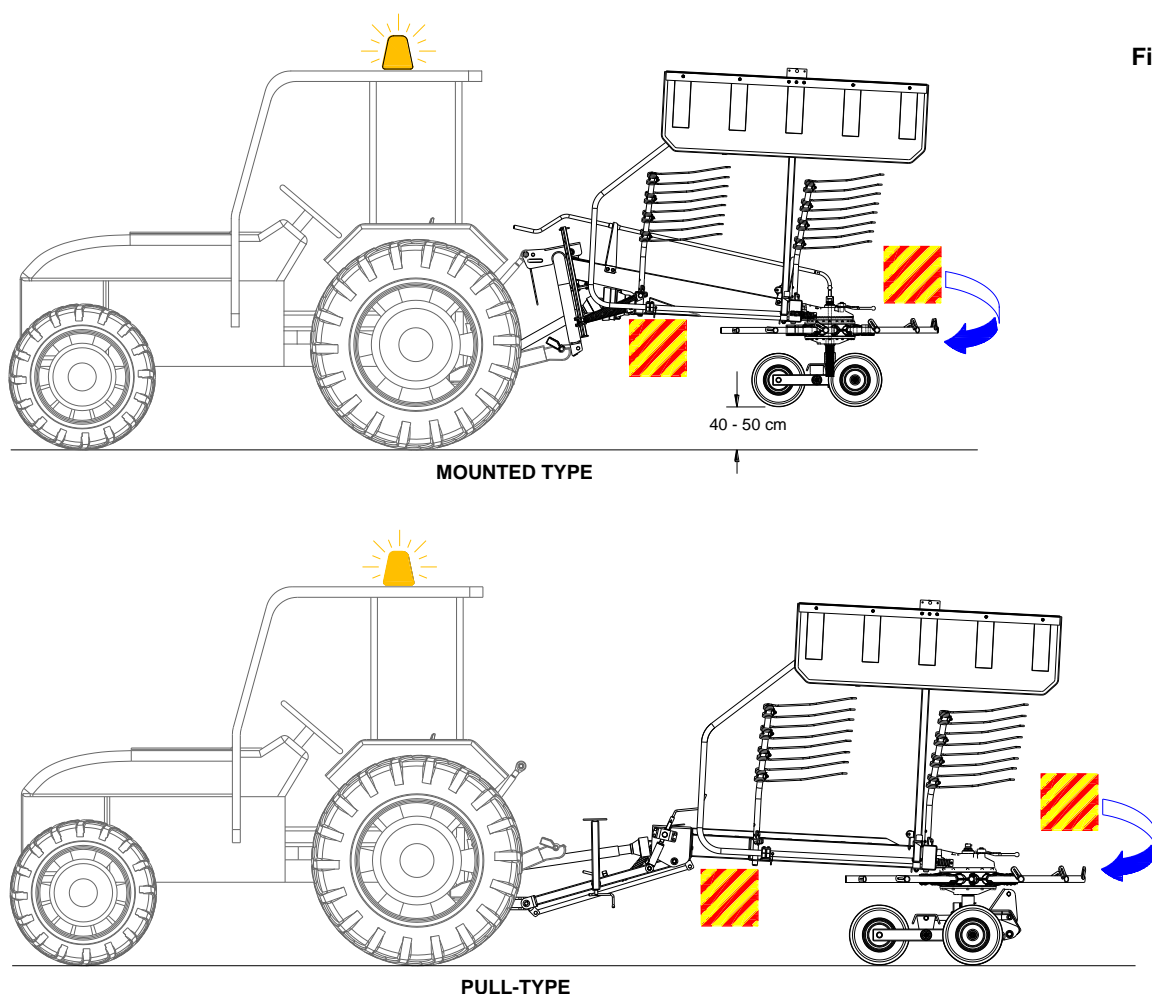
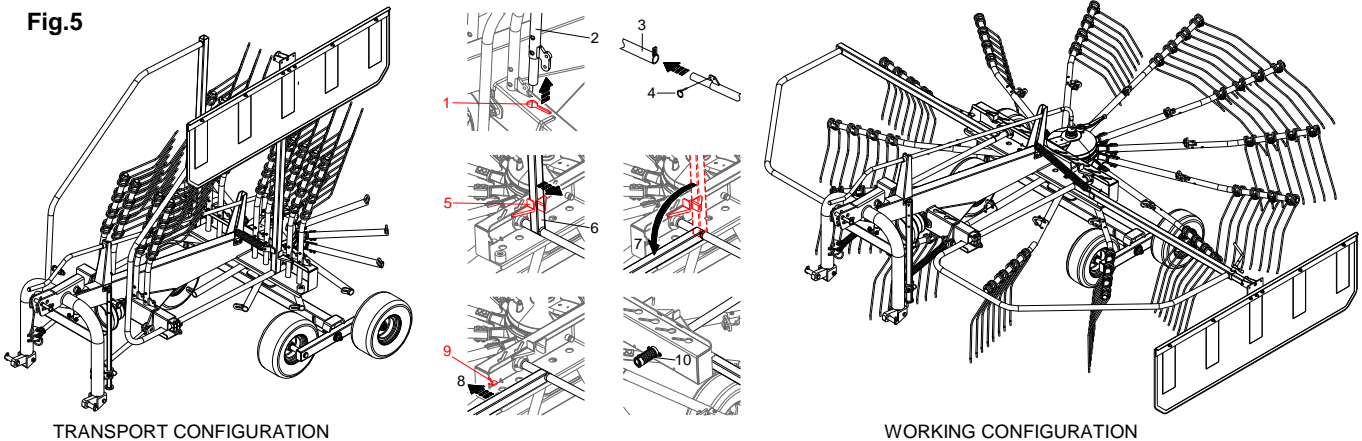

Fig.4



Fig.5



TRANSPORT CONFIGURATION

WORKING CONFIGURATION

**Moving on fields:** inside them the machinery must not activate any luminous signal or buzzer or display any type of panel. The windrow rotary rake must assume the **working configuration** only before operating.

**Working configuration** (both mounted and pull-type - fig.5):

- one at a time, remove tine-holder arms (2) from respective supports on frame (1) and place them in each housings on work rotating unit (3) to then block them by using safety pin (4);
- first from a side and then from the other: pull forward, towards tractor connection, the side protection screen (6), so to unhook it from the mechanical block (5) by using for transportation;
- keeping it still pulled, rotate it downwards, as indicated in figure (7), and release it only when it is placed on the frame so to be blocked by its relative work mechanical block (9). When the screen (8) is released, an appropriate spring (10) will takes it back to the initial position. **Note:** on the left side of the windrow rotary rake, the mechanical block is not set. During the process, the side deflector weight keeps the side screen in position;
- for the use and the relative operating adjustments, to consult the following paragraph.

### B.3 Intended use and warning of employ

The windrow rotary rake is an agricultural equipment used to harvest any other type of previously cut forage, with formation of windrows.

The rake can be either mounted or pull-type. The **mounted** type can work only if installed on any agricultural tractor equipped with 3-point universal hitch and hydraulic lift. Whereas, the **pull-type** must be connected to the towing hook installed behind each tractor. The operation is common for both types and it is obtained both by effect of the tractor towing and by effect of the rotation of them working units. This rotation is provided by a cardan shaft coupled to the tractor PTO. The arm rotating motion and the action of tines allow to realise even and well ventilated windrows.

On the **pull-type** rake there are two hydraulic cylinders, which operation allows to adjust the tine adaptation to the ground and to lift them for the tractor change of direction at the end of the field or in reverse. These cylinders are powered by the tractor auxiliary hydraulic circuit, through hoses equipped with quick couplings and controlled by a special lever placed inside the cabin.

The windrow rotary rake must be used only by adult, qualified and trained personnel and aware of the instructions contained in this manual. Safety is of prime importance for the personnel who use the equipment or who perform repairs or maintenance. Given that the provided instructions cannot cover all possible working situations and related danger, personnel should always use caution and common sense.

**Before starting the tractor and begin working, it is important:**

- verify that the equipment has been correctly installed on the tractor;
- verify that all locking and safety devices are present and undamaged;

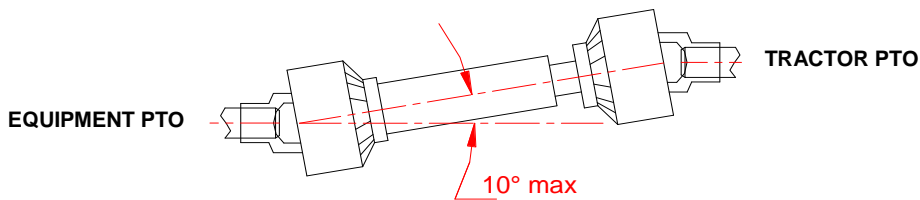

Fig.6

- on the tractor PTO, verify that the rpm is of **540** and that it rotates clockwise. Moreover, ensure it is disengaged.

**IMPORTANT**

**PTO must never be engaged with the engine off and with an inclination higher than 10° between joints of the two connections (tractor/windrow rotary rake - fig.6);**

- verify that the cardan shaft is correctly installed and all blocking and safety devices are present and undamaged. **Should one of these be not installed or non-approved devices be mounted, the Manufacturer warns the Customer to not use such shaft because it is forbidden;**
- do not use the equipment if failures or damages are present especially on the protective devices;
- **only for the mounted type** - lower slightly the equipment to the ground by using the tractor hydraulic lift. Avoid violent impacts, which may provoke damages to the structure or components;
- perform the daily maintenance tasks (described in the relative paragraph). For such purpose, remind that any kind of

intervention (check, adjustment, maintenance, etc.) **must be performed with the tractor stopped, with PTO disengaged, with its engine off;**

- verify that the position of the side deflector and of the tines in relation to the ground. Should their adjustment be required, consult the respective paragraph;
- verify that no people or animals go in the **dangerous zones** of the equipment (shown in **fig.7**), because they are not conscious of possible dangers;
- the operation of the equipment is allowed in **good lighting and visibility conditions**. Should these conditions lack, even partially, it is recommended to interrupt the working process as normal safe conditions would not be respected. Work should only be restarted if the good visibility and lighting conditions are restored. Do not use the equipment if failures or damages are present.

**During the working process the operator in tractor cabin must observe the following precautions:**

- the tractor must proceed in straight line, avoiding abrupt movements (sudden

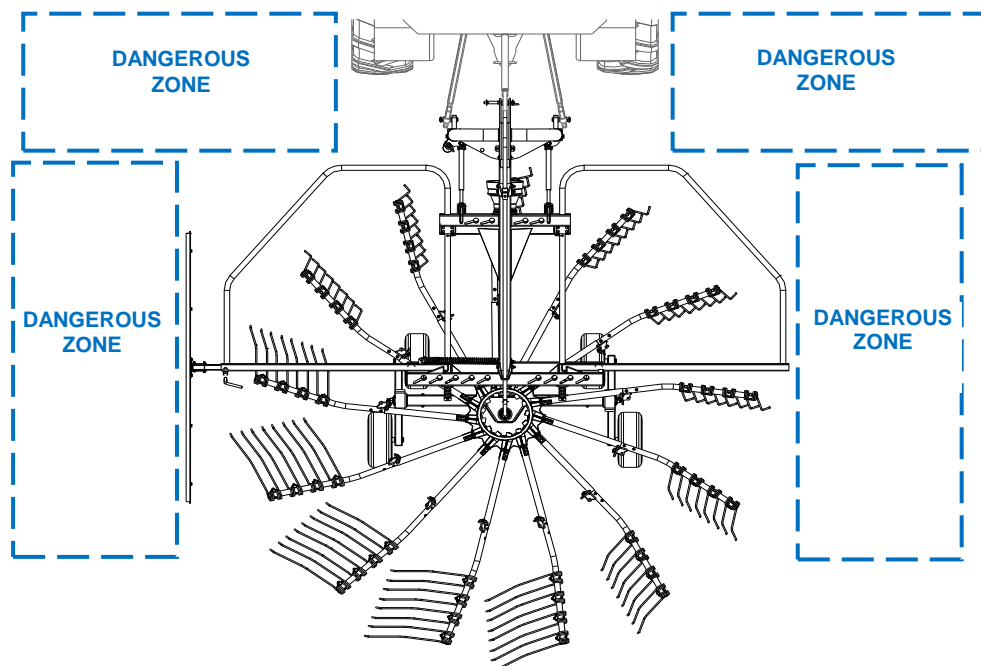
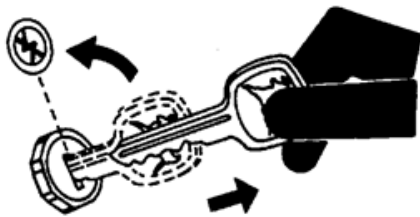

Fig.7

accelerations and/or changes of direction).  
**The tractor speed must not exceed the limit of 10 - 12 km/h (6.2 - 7.46 MPH);**



- **the operator in the tractor cabin must never abandon the tractor leaving its engine on.** Even for short working breaks, they must always stop the tractor, switch off its engine and remove the ignition key from the dashboard;
- during working breaks, the operator must never allow non-authorized/qualified personnel to replace him;
- before reversing with the tractor or for changes of direction at the end of the field, the operator must always verify that the windrow rotary rake is not in working configuration and that its teeth are lifted at least 30 cm from the ground. For the **mounted** type, all the equipment must be lifted by using the tractor hydraulic lift, whereas for the **pull-type** the entire frame must be lifted, by hydraulic drive, controlled by one of the tractor circuit levers from the cabin (see also paragraph D2.8 Change of direction or in reverse). The equipment may be seriously damaged if the tines are not lifted;
- the rake operation does not produce enough noise to allow the use of the acoustic protections (earplugs, earphones, etc.), instead the tractor can produce it. Therefore, consult the use and maintenance manual of the tractor;
- vibrations produced by the equipment that reach the operator are of low intensity and have a frequency that result lower than levels tolerated by human body. **However, it is important to keep transmission bodies and gears always lubricated. It is also important to often verify that screws are always tighten to avoid excessive vibrations.**

**Stop immediately the working process if:**

- it is near to resistant objects, such as drains, wells, shafts, etc., as the contact may break the teeth, which pieces can be projected around at a very high speed;

- noisy vibrations coming from the equipment are felt. To avoid any damages, stop the tractor, disengaged the PTO, switch off the engine, and, if feasible, detect and remove the inconvenient by observing the safety regulations;
- on the **pull-type** model oil leakage is detected. Do not seek the leakage with bare hands, but by using a cloth or protection gloves. Under pressure oil may penetrate in the skin causing serious infections.

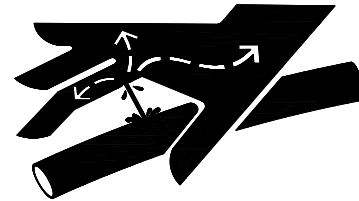

#### B.4 Reasonably foreseeable misuse and limit of employ

A different use from that one described in the previously paragraph **is considered improper and therefore forbidden.** In addition, the technical characteristics of the equipment must not be modified in any way to alter its performance. **In this case, both the equipment warranty and the Manufacturer liability would immediately become void**

**Visibility:** in conditions of insufficient visibility (fog, dust, smoke or other): it is advisable to stop the tractor and to wait until that fog, dust or other goes away. Operate at the same way in case of **rain.**

**Dangerous zone:** if, during the working process, a people or an animal go in one of the dangerous zone (see previously paragraph), the tractor driver must immediately stop the working process and provide to distance the intruder. At the same way, during the adjusting and/or maintenance tasks, the outsiders must not stay or move in the proximity of the equipment.

**Do not use the equipment if:**

- the material to cut is humid or wet. In these conditions, it becomes sticky and it easily gather on the tines affecting the operational function;



- **Its operation must take place nearby masonries. In these cases, besides the possibility to damage the tines, a dangerous projection of relative residuals may occur as well;**



For any doubt concerning the use of the windrow rotary rake and not mentioned in this manual contact directly the Manufacturer.

### B.5 Responsibilities of the operator

Each operator becomes liable for the damages caused to themselves, others, animals or damages to the things if they proceed with an incorrect use of the equipment and/or not conform to the instructions contained in this manual. Consequently, **the responsibility of the Manufacturer would immediately be void if the operator:**

- use the equipment in improper or incorrect way;
- use the equipment under the effect of alcohol, medicines, drugs or if tired or sick;
- has not been properly trained or has not read the operator instructions in this manual;
- does not respect the current road laws;
- not having previously verified the required

requirements, the coupling of the equipment to the tractor is not suitable (different power or characteristics to the those ones indicated in the table of the technical data);

- has not performed the foreseen maintenance tasks;
- has modified the equipment;
- has used non original spare parts or not right for the model.
- do not wear radio or music headphones while operating machine;
- wear close fitting clothing and safety equipment appropriate to the working process.

### B.6 Safety labels

In addition to the instructions contained in this manual, adhesive labels have been applied on various parts of the equipment to help operators. These labels illustrate the safety rules that should be observed.

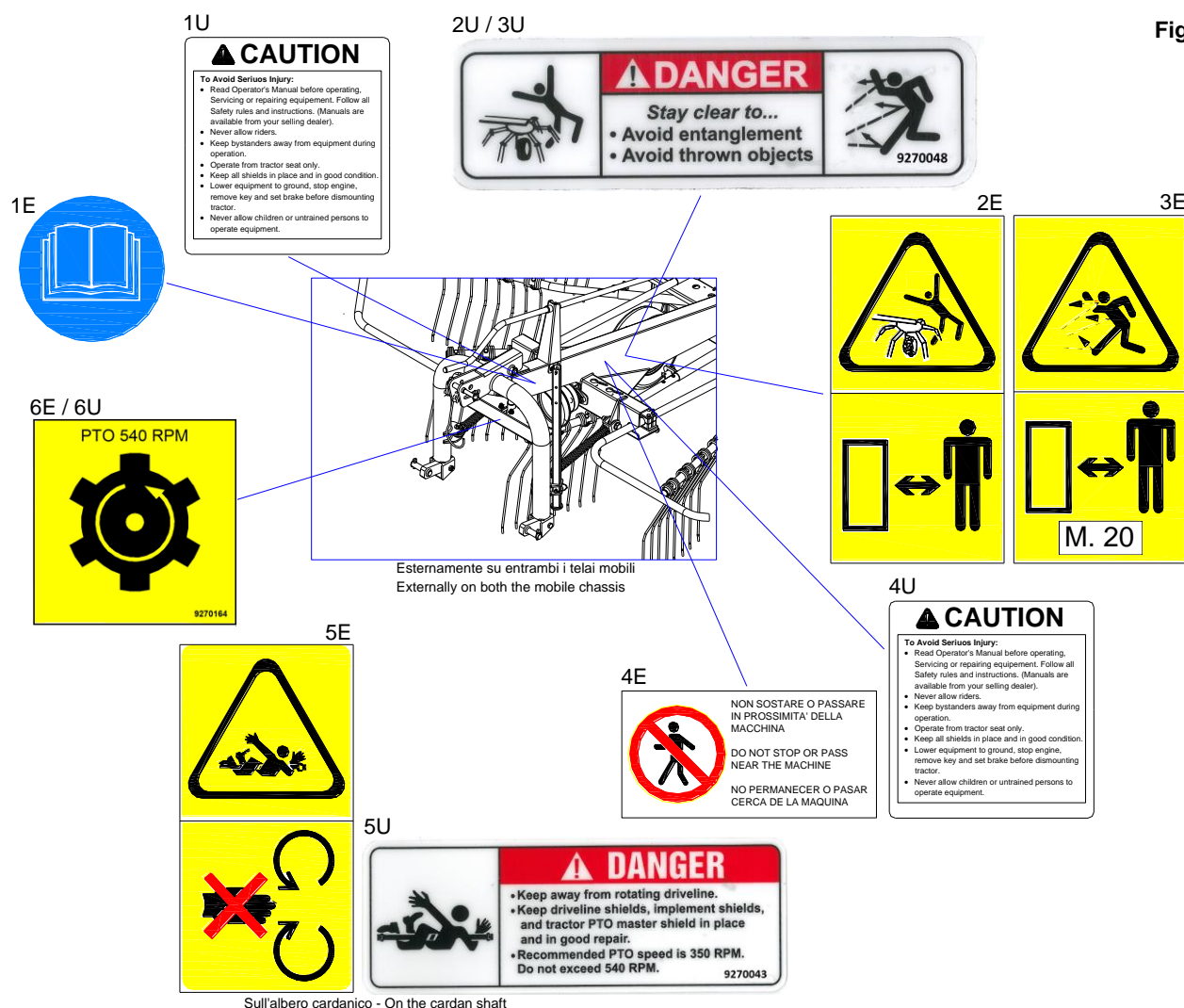

Fig.10

The shape and colour of the labels vary based on the rules. In addition to containing a danger or prohibition sign, other rectangular labels provide additional information about the safety rules that must be observed. The rules illustrated by the labels affixed to the equipment (**fig.10**) are as follows:

**1U - obligation** to read the use and maintenance manual;

**2U / 3U - danger of hooking or entanglement.** With rotating arms, their tines may hook on to clothes or other objects worn by personnel in charge;

**2U / 3U - danger of flying objects.** Objects presents in the operational field may be caught and thrown by the tines. Keep a safety distance of 20 m.;

**4U - prohibition to stand or transit.** It is forbidden for persons not in charge to stand or move inside the operational area of the windrow rotary rake, when this is running. Should it be necessary to move inside the operational area, keep a safety distance (20 m). Whereas, when the rake is in transport configuration, it is better to do attention to the tines, which being in lifted position and then sticking out should be a danger for who transit near the equipment;

**5U (on cardan shaft) - danger of hooking or entanglement.** With the rotation of the shaft, clothes or other objects worn by staff may be hooked ;

**6U** - verify that the rpm number set at the tractor PTO output is of 540 rpm/min and that it rotates clockwise.

#### **IMPORTANT**

The safety and instruction labels must be replaced before they become illegible. If this happens, the operator cannot use the carted wheel rake until a new label is applied. Similarly it is utterly forbidden to remove the safety or instruction labels placed on the machine. In any circumstances in which this occurs the Manufacturer disclaims all responsibility because the machine would not meet the safety standards with which it was designed and manufactured.

The labels similar to these present on the equipment are available from the Manufacturer. Call the Customer service of H&S Dealer to ask for replacements. It is advisable, during the equipment delivery verify the presence and the status of the labels.

#### **B.7 Noise levels**

The device produces little noise other than that of its moving mechanical parts and has no motor. Therefore, the operator does not need any acoustic protection (ear plugs, muffs, etc.). As for the noise produced by the tractor, to consult the proper operator's manual.

#### **B.8 Residual risks**

- Injury of lower limbs and/or bodily: loss of stability when parking caused by the missed installation of the bearing foot.

## C. INSTALLATION

### C1 Preliminary information

The **pull-type** windrow rotary rake can be installed on any agricultural tractor provided with towing hitch and rear auxiliary hydraulic couplings; whereas the **mounted type** can be installed on any tractor provided with rear universal 3-point hitch and of coupling and hydraulic lift. For the intervention the equipment must be placed inside an area with flat surface, arranged for the installation. The operator performing the intervention must be aware of the relative safety regulations and must work with the utmost attention and caution.

### C2 Installation to tractor

- **Mounted type (fig.11):** the operator must slowly approach the tractor to the windrow rotary rake, positioning it so to facilitate its centring.

#### IMPORTANT

The holes in the tractor attachment must be aligned with those on the rake attachment with maximum care and attention.

Once the manoeuvre is completed, the operator stops the tractor, leaves the lift in low position, engages the parking brake, in case disengages the heavy pull, removes the ignition key from the dashboard, gets off of cabin and works as follows:

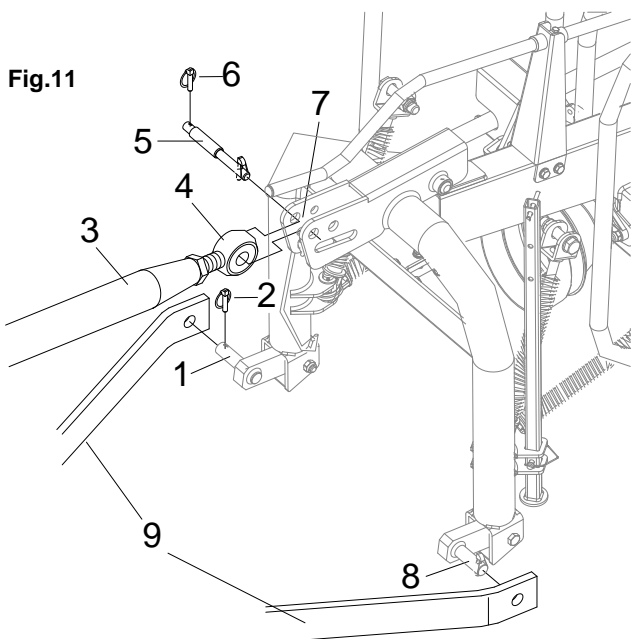

- inserts lift arms (9) in the appropriate housings (low pins 1 and 8) on the frame of windrow rotary rake (6) and blocks them, one by one, by using safety pins (2);

- (should it not be present on the tractor) places the adjustable tie-rod (3) in the appropriate housing of the tractor 3<sup>rd</sup>-point ("heavy pull" hole) and then fastens it to the tractor by using the provided pin;
- loosens or tightens the tie-rod body of the windrow rotary rake, leaving volute (4) free, until it coincides with the housing on equipment frame (7);
- fastens the tie-rod with pin (5), which subsequently blocks with safety pin (6);
- once performed these operations, the operator gets on the tractor and lifts the equipment by activating the hydraulic lift lever and supported by another operator from the ground, until the PTO has the same height of the tractor. Afterwards, stops the tractor again, blocks the hydraulic lift lever and adjusts the tie-rod (by acting on his body), until the frame of the windrow rotary rake is perfectly vertical, then he tightens the lock nut;
- blocks the arms of the hydraulic lift with the tie-rods or chains they are equipped with.

Once performed the centring, the same operator lifts bearing foot (12 - fig.12) in a more suitable and safe position, both for the transport phase and for the subsequent working phase. For this lifting, the operator removes pin (11) to release locking pin (10) and then removes the latter from the foot holes. He lifts the foot up to the lowest hole, as indicated in the figure and tightens it with the locking pin and relative pin.

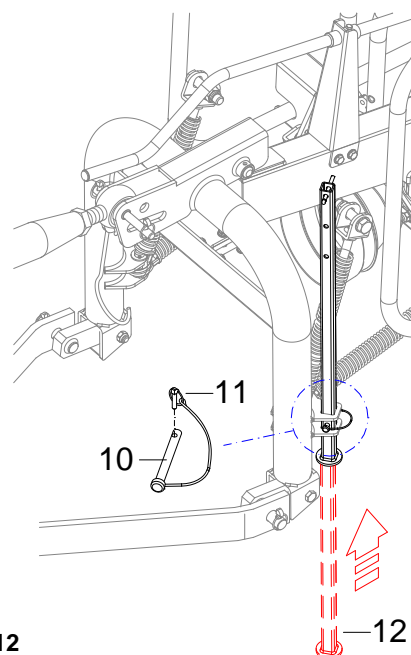

Fig.12

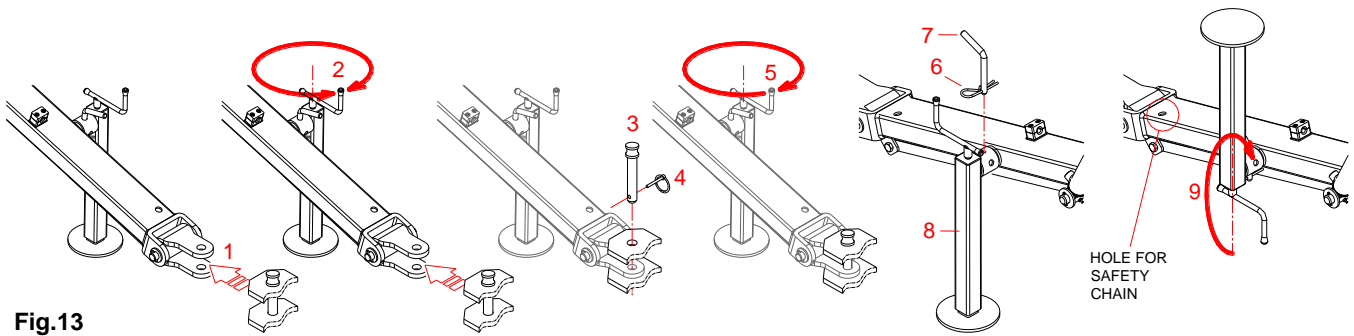

Fig.13

**Cardan shaft:** for the instructions concerning to its installation and adjustment consult to its use and maintenance manual.

- **Pull-type (fig.13):** the operator must move the tractor slowly to a position where the joints can be easily aligned (1 - fig.13).

#### IMPORTANT

The holes in the tractor attachment must be aligned with those on the rake attachment with maximum care and attention.

When the tractor is near the rake hitch, turn the lever on the bearing jack (2) to raise or lower the rake hitch and bring it parallel with that on the tractor. You can then insert the locking pin (3) through the respective holes in the attachments, as shown below, and secure it in place with the respective safety pin (4).

Next, turn the lever (5) on the bearing jack to raise the latter as high as necessary to move it from its position to that required for trailing the rake.

To move the jack (fig.13): remove the R pin (6), take out the handle pin (7) and take the jack out of its housing (8). Next, turn the jack counter-clockwise (9) as illustrated and re-insert it in its housing. Insert the handle pin in its new housing and fasten it with its respective R pin.

**Note:** near the tow hitch there is a hole where to connect the safety chain, which must be successively fastened to the tractor. The application of this chain is not mandatory in Countries members of the European Union, however it is in other Countries, as U.S.A..

### C3 Installation and adjustment of cardan shaft

- **Installation:** strictly observe instructions relative to installation indicated in its own use and maintenance manual.

#### IMPORTANT

Before installing the cardan shaft, verify that this has the requisites required for the type and power to transmit according to the rpm of the PTO. If required, verify also the tractor use manual.

Should this not be used, is saying not installed on the PTO of the tractor but only on the windrow rotary rake one, lay the cardan shaft on the support located on the **mounted type** or on the towing bar of the **pull-type**.

- **Adjustment:** the cardan shaft (both provided with the equipment and sold as accessory) has a standard length. So it must be adjusted to the tractor where the windrow rotary rake is installed. For this operation, proceed as follows:

- remove protection devices from the cardan shaft;
- remove the two parts that make up the shaft and join a part to the windrow rotary rake PTO, by clicking the spring safety pin and the other part to the tractor PTO, by clicking the spring safety pin as well;
- place the two parts of the cardan shaft beside and find the minimum sliding length (L). Should the shaft be too long, shorten the two external plastic protection pipes, which must have the same size, and then the internal metallic ones. Smudge the cut parts and lubricate the internal parts.

#### IMPORTANT

When the cardan shaft is pulled out at its maximum, the two pipes must overlap for at least 15 cm. When it is inserted at its maximum, the minimum gap allowed must be 4 cm.

- remove the two parts of the cardan shaft from their connections (on the tractor and windrow rotary rake) and assemble the

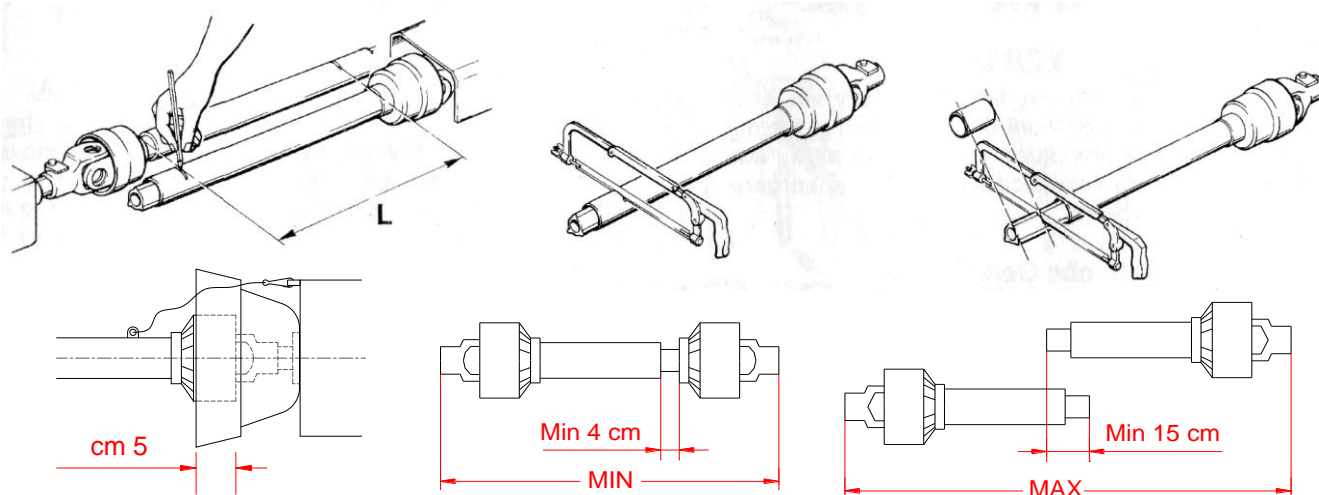

shaft, by placing a part completely inside the other;

- join again the two ends of the cardan shaft to the relative PTO by clicking the relative spring safety pins;
- block the protection pipes by using appropriate chains to prevent their rotation both on the tractor and on the windrow rotary rake. The overlap between guard and cardan shaft must not be lower than 5 cm.

Now, without activating the tractor PTO, all the equipment can be transported to the place of use.

**Note:** by using the equipment on another tractor requires the adjustment of the cardan shaft. Proceed following the instructions indicated in this paragraph.

#### C4 Hydraulic hoses

The adjustment of the tines in relation to the ground (which implies lowering and lifting the entire frame, including the work rotating unit) is determined by the retraction and extension of the two appropriate hydraulic cylinders. These are powered by the tractor auxiliary circuit and so controlled by a lever, located in the cabin. Thus, the tine adjustment cannot be carried out if previously the jack pipes (provided with quick coupling, as indicated in the figure)

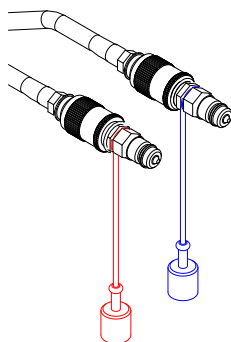

are not connected to the correspondent connections of the tractor auxiliary circuit.

#### C5 Removal

To remove the rake from the tractor, follow the above instructions in reverse order. The hydraulic connections have to be removed before the rake.

### ! WARNING

Before removing the hoses, remove the hydraulic pressure inside the circuit by acting the corresponding lever in cabin.



#### C6 Storing the rake

The Customer must set aside a large and easily accessible area on his premises where the rake can be stored. How to store the rake:

- if not already done, have the windrow rotary rake assume the work configuration;
- park the equipment in a safe and isolated place, on a flat and consistent surface;
- **mounted type:** using the tractor hydraulic lift, rest the equipment on the ground;
- if not already done, adequately position the support foot for the parking phase;
- remove the tractor from the windrow rotary rake;
- protect the equipment with a sheet.



## D. OPERATION and USE

### D1 Working configuration

The windrow rotary rake will be driven on to the work place, according to the regulations described in paragraph B2 and before using the equipment, the operator will perform the following interventions:

- make certain that the PTO is disengaged;

**IMPORTANT**  
**Tractor PTO must never be engaged with the engine switched off;**

- **only for the mounted type:** by activating the relative lever, lower the tractor hydraulic lift until the wheels of the windrow rotary rake touch the ground;
- switch off the tractor engine, engage the parking brake, remove the ignition key from the dashboard and go down from cabin;
- provide to put the equipment in the working configuration (**fig.17**):
  - a. one at a time, remove tine-holder arms (2) from the respective supports on frame (1) and place them in the housings on work rotating unit (3) to then block them by using safety pin (4);
  - b. first on the right side and then on the left one: pull forward the side protection screen towards tractor connection (6), so to unhook it from the mechanical block for transportation (5);
  - c. keeping it also pulled, rotate it downwards, as indicated in figure (7),

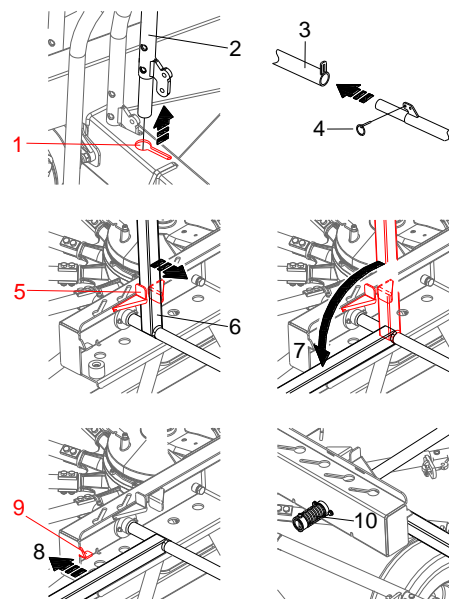
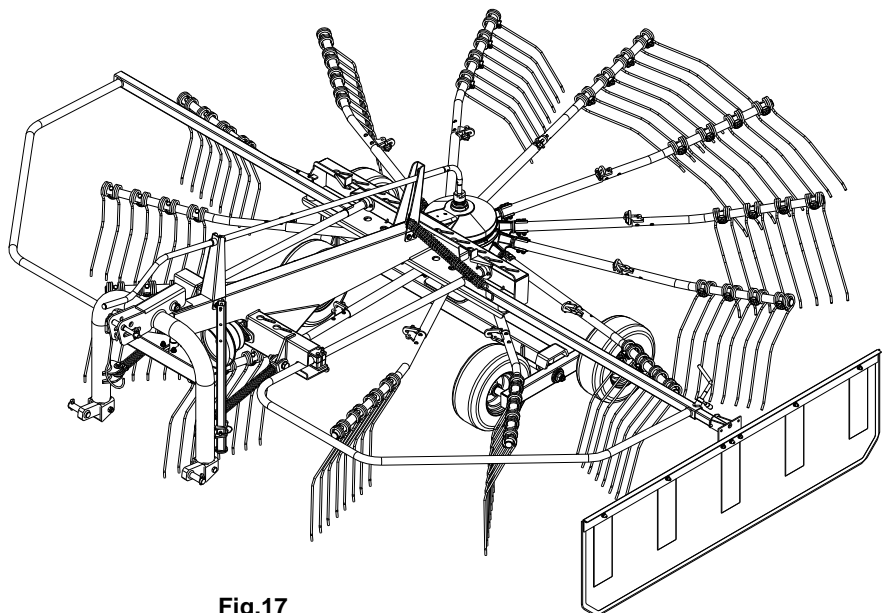

Fig.17



and release it only when the same is placed on the frame so to be blocked by its relative work mechanical block (9). When the screen (8) is released, appropriate spring (10) will take it back to the initial position;

- d. on the left side, before lowering completely the protection screen, open the side deflector (**fig.18**). Therefore, remove the safety pin from the pin that blocks the deflector rotation. Remove the pin from its housing (11) and rotate deflector (12) of 90° upwards, as indicated in the figure. Complete lowering the side protection screen. **Note:** on this side of the windrow rotary rake, the mechanical block is not set. The side deflector weight keeps the screen position during the process;

Fig.18

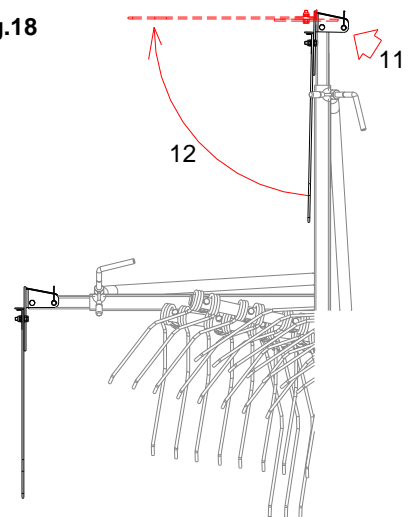

- e. make certain that the bearing foot is in a safety position. It must be already in this

Fig.19

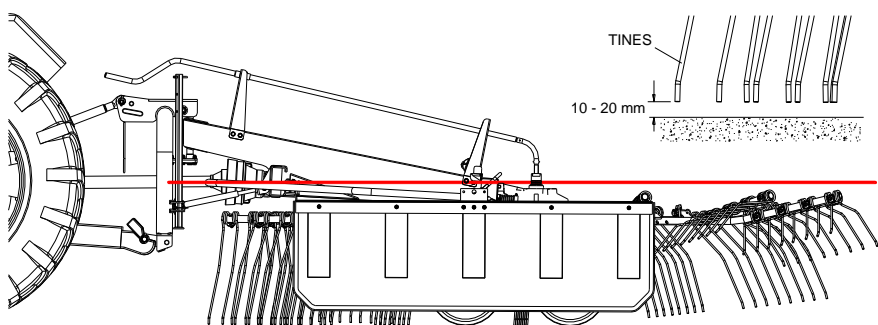

position, because this intervention completes the installation of the windrow rotary rake on the tractor. Should it not be, follow the related instructions indicated in paragraph C2 Installation to tractor;

- make certain that there are no persons or animals within the action range of the equipment, otherwise move them away;
- get up on the tractor, start the engine, disengage the parking brake and engage the PTO.

## D2 Working process

Harvesting process starts when the tractor moves forward and with the work rotating unit in operation. By brushing the ground, tines scrape the surface and collect the cut forage, forming a left side windrow, which is regular and even, as indicated in the **fig.20**. In order to obtain a satisfying result, the windrow rotary rake must work in parallel to the ground and tine adjusted at a distance of  $10 \div 20$  mm from the ground (**fig.19**). Instead, the side deflector position determines the windrow width.

Proceed for some meters and then verify the process result. Should the operator require one or more adjustments, follow the instructions indicated in the relative paragraphs.

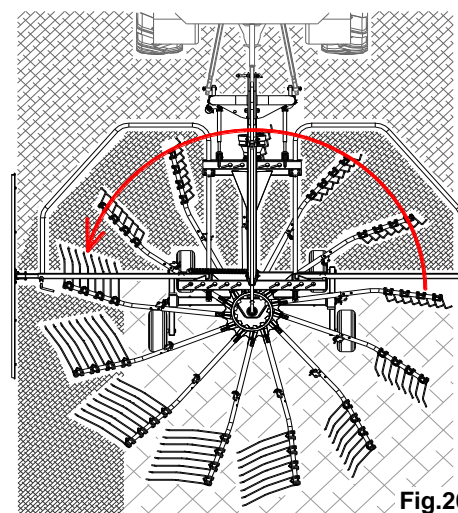

Fig.20

### IMPORTANT

Except when otherwise written, all adjustments must be performed with the tractor engine switched off, PTO disengaged, parking brake engaged and ignition key removed from the dashboard.

## D3 Adaptation of the parallel windrow rotary rake to the ground

Perform this adjustment if the equipment does not work in parallel to the ground.

- **Mounted type (fig.21):** to perform such adjustment, activate the adjustment tie-rod, located between the tractor and the third section of the windrow rotary rake, by loosening or tightening its body and manoeuvring the appropriate lever, as indicated in the figure. By rotating the lever counter-clockwise (direction **A**) the tie-rod extends, pushing the equipment frame downwards. By rotating the lever clockwise (direction **B**) instead, the tie-rod shortens, pulling the frame of the windrow rotary rake upwards.
- **Pull-type (fig.22):** to perform such adjustment, activate the front jack, located between the towing connection and the frame, by loosening or tightening a worm

Fig.21

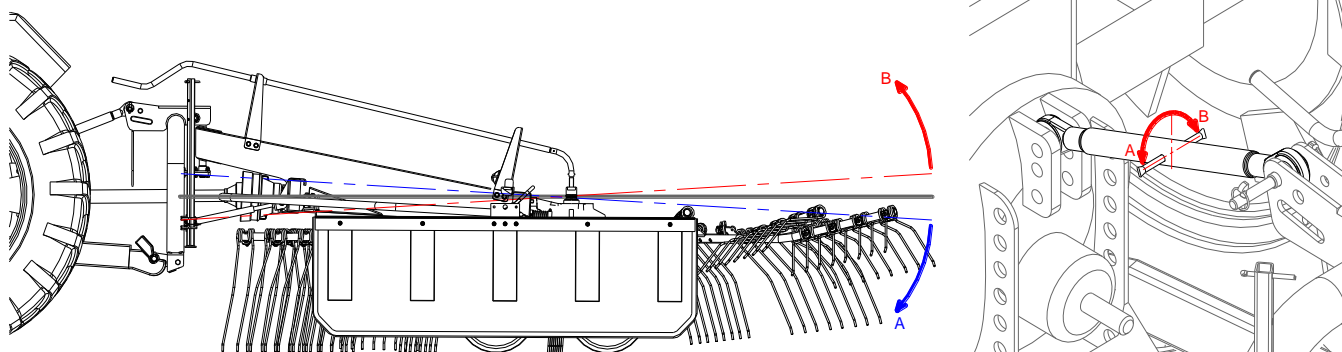

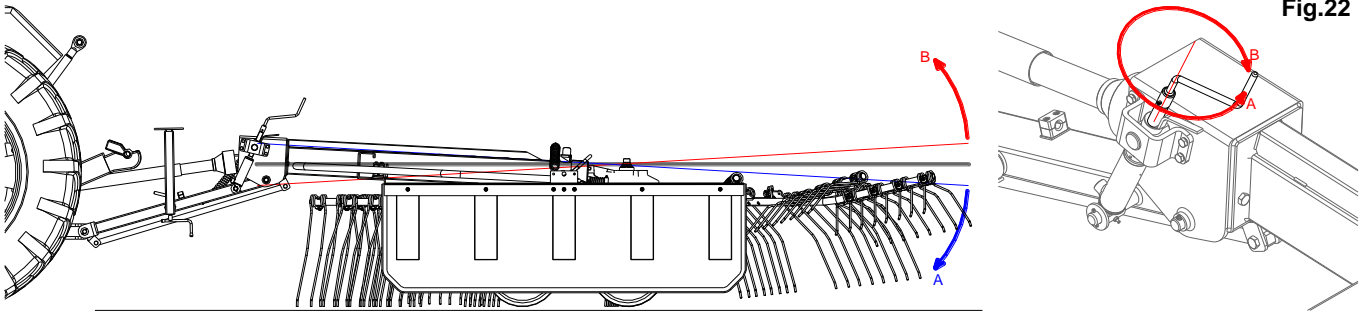

Fig.22

screw installed in it and manoeuvring an appropriate lever, as indicated in the figure. By rotating the lever counter-clockwise (direction **A**), the equipment frame lowers, whereas by rotating the lever clockwise (direction **B**) it lifts

**D4 Adjustment of the windrow tine distance from the ground**

- **Mounted type (fig.23):** to lower the tines and so reduce their distance from the ground, rotate counter-clockwise the appropriate handle (**B**), located nearby the third section, as indicated in the figure. If they touch the ground, they must be lifted by using the tractor hydraulic lift (**A**), activated by the appropriate lever located inside the cabin. **Note:** in theory, to lift the tines from the ground, the handle should rotate clockwise, but in practice, the weight of the rotary unit with arms does not allow this operation. Therefore, use the hydraulic lift.

- **Pull-type (fig.24):** to adjust the distance of the tines from the ground, adjust the position of appropriate adaptor (**3**), located in its housing, under the rotary unit, as indicated in the figure. First, lift completely rotator unit with arms (1), by manoeuvring the relative tractor service lever from the cabin, and then safely block it, by placing a piece of wood or metal under it (2), as indicated in the fig.24, so that the unit cannot lower in any case. This application is required, because to adjust the adaptor position, an operator must work under the rotator unit. In this position, he must remove the R-pin that blocks the handle pin (4), extract it from its housing and place the adaptor by sliding it vertically in its housing, as indicated in the figure. The holes on the adaptor and those present in the housing are located so to easily obtain the desired height. Once the adaptor is placed, the operator inserts the handle pin again in the corresponding holes and then it blocks it, by using the relative R-pin.

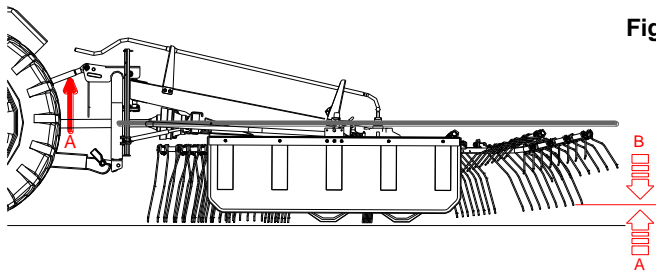

Fig.23

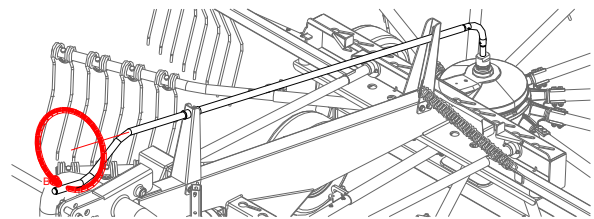

Fig.24B

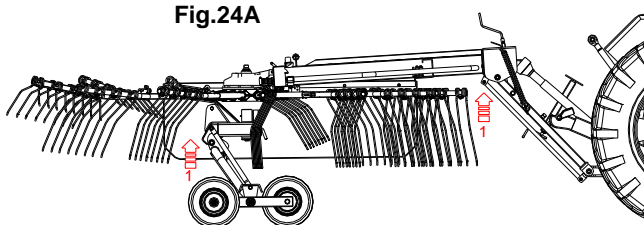

Fig.24A

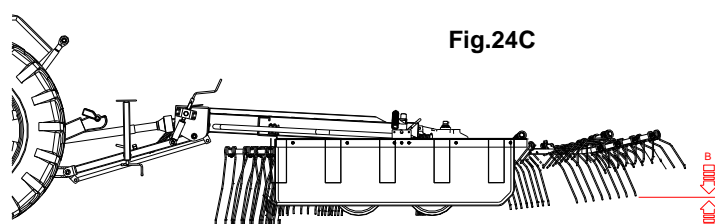
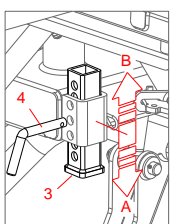
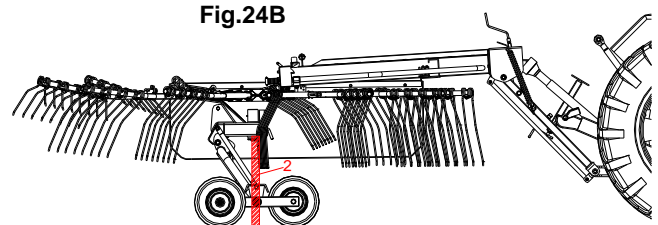
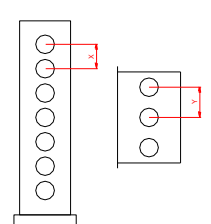
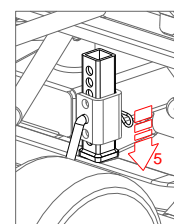

Fig.24C





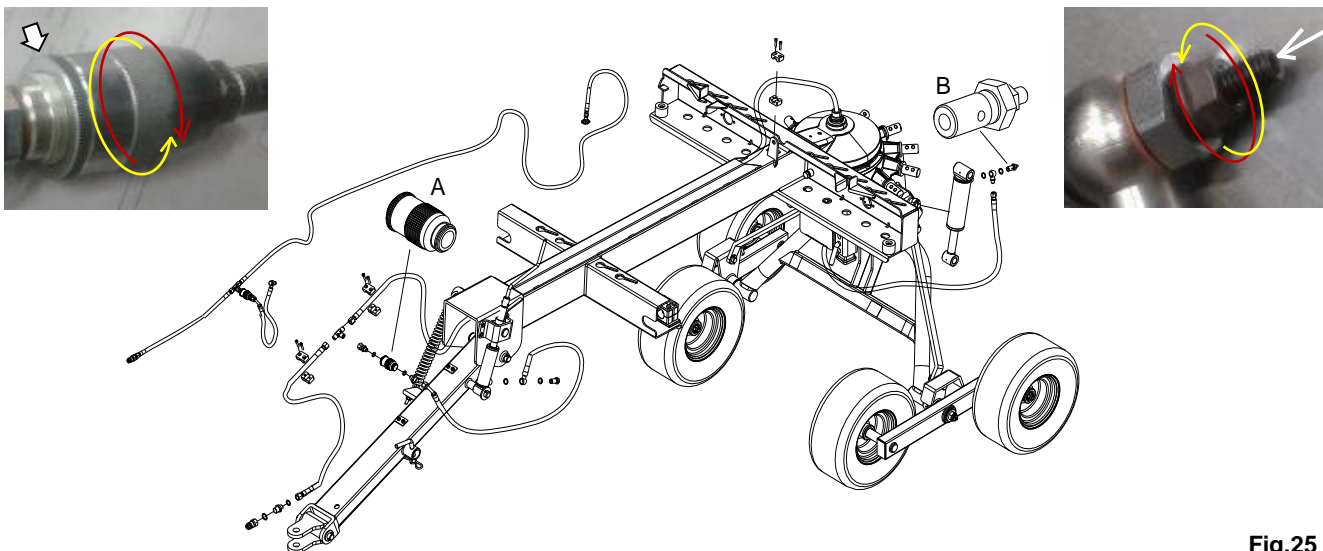

Fig.25

Then, the operator removes the safety piece of wood or metal and lowers completely the rotating unit, by manoeuvring the lever from the cabin, until the adaptor base does not touch with the wheel axle (5). Verify the new distance between windrow tines and ground.

#### D5 Adjustment of the hydraulic cylinder moving

**A. Flow adjusting valve of frame (fig.25):** if the lifting of the frame did not result parallel to the ground, adjust the valve by manually rotating the knurled part:

- unscrew the locking ring nut;
- manually rotate the valve toward right (+) or toward left (-);
- lock the valve in the select position by tightening the ring nut.

**B. Flow adjusting valve of rotor (fig.25):** if the lifting of the rotor results too much fast or too much slow. Adjust the valve by using an Allen key:

- unscrew the locking nut;
- manually rotate the Allan key toward right (+) or toward left (-);
- lock the valve in the select position by tightening the nut.

#### D6 Adjustment of the side deflector distance from the ground

To perform the adjustment (fig.26):

- loosen completely the nuts of the screws that blocks the deflector on its support;
- one by one, remove screws (6) paying attention not to drop the deflector;
- place the deflector drilled rod in the desired position, referring to the holes on its support (7);

- place the locking screws in the new holes and tighten completely the relative nuts.

Fig.26

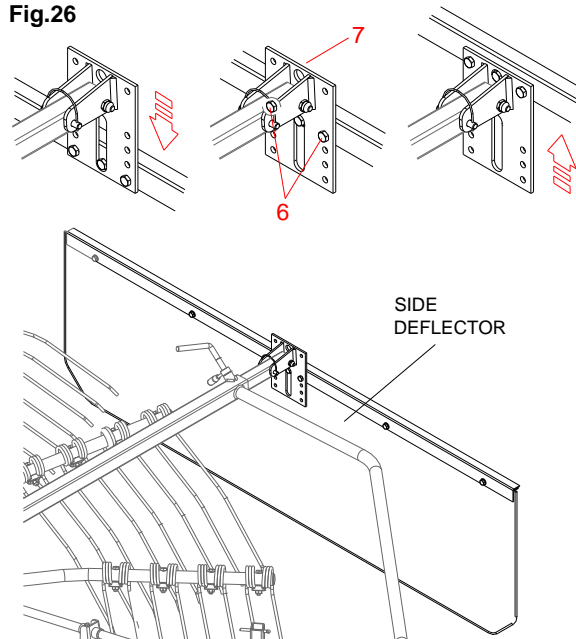

#### D7 Adjustment of the side deflector range

This adjustment is performed to form a more or less wide windrow, according to the cut forage quantity. The higher this is, the wider must be the windrow, so the deflector must be placed more externally. To adjust its excursion (fig.27):

- first loosen locking knob (by rotating it counter-clockwise) (9) and then handle pin (8), enough to slide horizontally the deflector in its housing;
- adapt the deflector excursion to the kind of windrow desired;
- lock its support again, by tightening first the handle pin and then the locking knob (by rotating them clockwise)

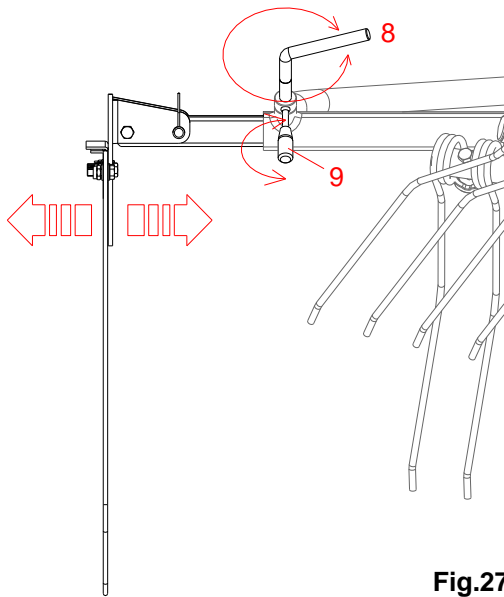

Fig.27

rake in the transport configuration, before moving.

For work breaks, even short, the operator must always:

- disengaged the tractor PTO;
- switch off the tractor engine;
- engage the parking brake;
- bring the gear lever in neutral or "idle" position;
- remove the ignition key from the dashboard.

To store the equipment, follow instructions described in paragraph C6.

### D8 Change of direction (U-turn)

At the end of the field, when the tractor with the windrow rotary rake must invert direction or in the event it must go in reverse for a short distance, windrow tines must be lifted from the ground.

- **Mounted type (fig.28):** all the equipment must be lifted by using the tractor hydraulic lift (1), until tines will be at 30 cm from the ground;

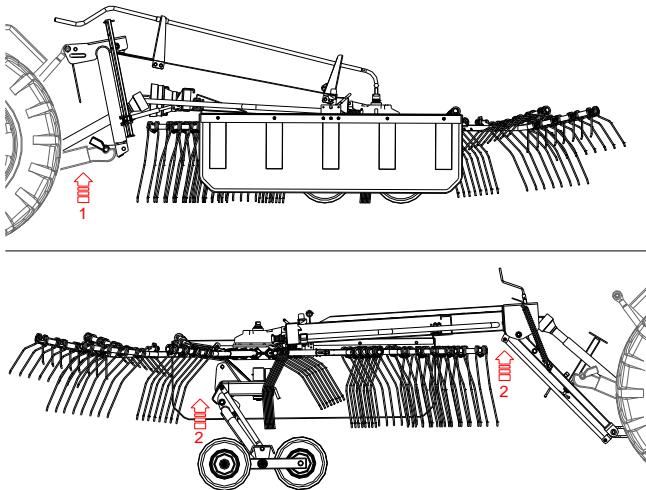

Fig.28

- **Pull type (fig.28):** the entire frame must be lifted by using the hydraulic lift (2), which is controlled by the corresponding lever of the tractor auxiliary circuit, from the cabin.

### D9 End of the work

Once work is completed and the tractor must return in its usual parking, put the windrow rotary

## E. MAINTENANCE

### E1 Warnings during maintenance

The windrow rotary rake is agricultural equipment that does not require particular maintenance, or relative programs. However, a periodical intervention is envisioned (described below) that, if scrupulously carried out by the Customer, will maintain the efficiency and work ability of the equipment unaltered, preserving it from every functioning damage.

The operator, who must be an adult, qualified and trained for these interventions, must observe the following:

### HAZARD

- any kind of intervention must be carried out on a flat surface, sufficiently lighted and free from any person, animal or object that may obstruct every manoeuvre. The equipment must be stable on the ground, the tractor stopped, the parking brake engaged, the engine off and ignition key removed from the dashboard. Should lifting the windrow rotary rake be required, safely block it, by placing a piece of wood or metal under it, as indicated in the fig.28;
- before working, for the operator's safety and to prevent damages to the windrow rotary rake, a clearly visible sign indicating "Machine under maintenance" must be applied on the tractor dashboard;
- the interventions, maintenance and repair, once started must always be completed and never post-poned;
- he must not work on memory, but always read the instructions in this manual and accurately follow them;
- the use of equipment to perform the maintenance interventions is subject to the relative accident-prevention regulations.

However, do not use the equipment improperly like, for example, using petrol to clean or pliers instead of an adjustable wrench.

Once maintenance or repair has been completed, clean the area from water, oil, grease, oily cloths, tools or other material.

### E2 Maintenance tasks

The times of intervention are merely for informative purposes and relate to normal conditions of use. They can therefore vary in relation to the type of service, the work environment (more or less dusty), seasonal factors, etc. The harder the functioning conditions of the equipment, more interventions are required.

GREASE  
NIPPLE



POINT TO  
LUBRICATE

Other maintenance tasks to be performed weekly (or after about 40 operating hours) are:

- grease top-up, by using an appropriate pump, in all grease nipples present on the equipment and identifiable by means of the adhesive labels, as shown at the side, applied near-by;
- check the fastening of nuts and screws blocking the various equipment parts;
- check the presence of the various safety pins and R pins blocking the various equipment parts;
- verify the structural integrity of all equipment parts, in particular those subject to wear like, for example, the tire wheels;
- **pull-type:** verify that all components of the hydraulic system do not leak.  
**Note:** both windrows rotary types are equipped with work rotating unit operating in

Fig.28

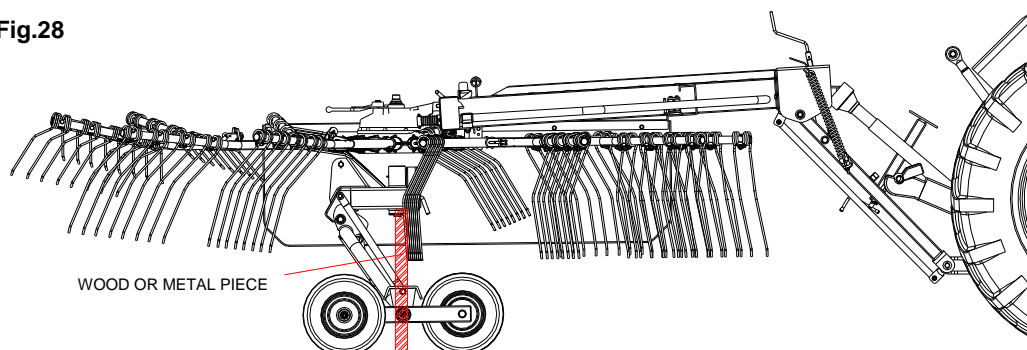

oil bath, this means that all components of the rotor are dipped in lubricant. Without oil, they are exposed to rapid wear and so to cam binding. Therefore, should leakages occur, verify its internal oil level. To verify this, loosen the level plug, placed at the head side and indicated in the figure. Should the oil not reach the lower part of the hole, its quantity is considered inadequate and so it must be filled up through the same hole until the oil will not escape. Only use oil type SAE 90 E.P..



**IMPORTANT**  
To avoid polluting, it is forbidden to disperse oil, lubricants, filtering cartridges or other toxic materials in the environment.

Scrupulously comply with the current dispositions for the disposal of liquid and solid substances.

- regarding operations on the cardan shaft, consult to its use and maintenance manual.

### E3 Replacement of window tines

Should the replacement of a pair of window tines be required (for wear or damage), loosen locking nut (5) completely, remove fixing screw (3) with relative tie-tine plate (2) from its housing and then remove tine pair (4) from the arm of equipment (1). Place the new pair and fix them by following removal instructions in reverse.

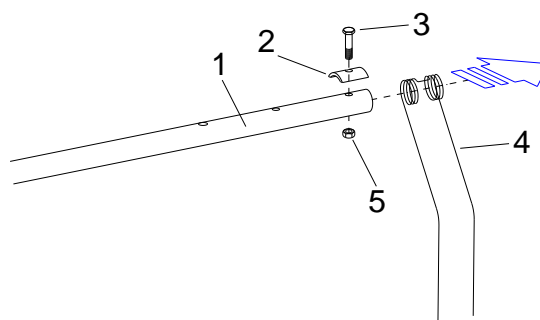

### E4 Troubleshooting

FAILURE OR INCONVENIENCES	CAUSES	SOLUTIONS
<b>Pull-type:</b> hydraulic cylinders move jerkily	Air in the hydraulic circuit	Run the windrow rotary rake in vain for a few minutes to drain the air in the hydraulic circuit.  Also verify the hydraulic oil in the tractor tank
<b>Pull-type:</b> a jack moves without the command for its activation	Jack gasket worn	Replace gaskets
Partial or inadequate forage harvesting	Windrow tines too distant from the ground	Adjust windrow tine distance from the ground (see paragraph D2.4)
Rapid wear of windrow tines	Tines a constantly touching the ground	Adjust windrow tine distance from the ground (see paragraph D2.4)

### E5 Machine demolition: disposal of materials

When the windrow rotary rake is placed out of service, the parts that might become dangerous for persons, animals and environment must be made harmless, if dispersed. The equipment materials, which are subject to a separate disposal are:

- iron
- lubricant oil
- rubber

The disposal of the above materials must be carried out respecting the legal dispositions in force in each individual Country.



---

Note:.....

.....

.....

.....

.....

.....

.....

.....

.....

.....

.....

.....

.....

.....

.....

.....

.....

.....

.....

.....

.....





*Assembly instructions*

**RR EVO 3P - PT**

rev.3a - 02/2017

### Assembly 1 - RREVO PT PULL-TYPE

ITEM	CODE	DESCRIPTION
1	18032360	AXLE TANDEM
2	18032240	TANDEM BLOCK
3	18032239	TANDEM
4	18032281	WASHER 60X23X5
5	3020222	SELF LOCKING NUT M22
6	3090102	GREASE ZERK M6X1
7	12170111	WHEEL
8	18033308	SUPPORT GEARBOX
9	12070315	EXTERNAL DUST COVER CAP
10	3030175	WASHER 30X17X3 ZN
11	3020204	SELF LOCKING NUT M16
12	18032247	HOLED PIN Ø30 L.370
13	3080103	ELASTIC PIN 6X40
14	3090101	GREASE ZERK M8X1

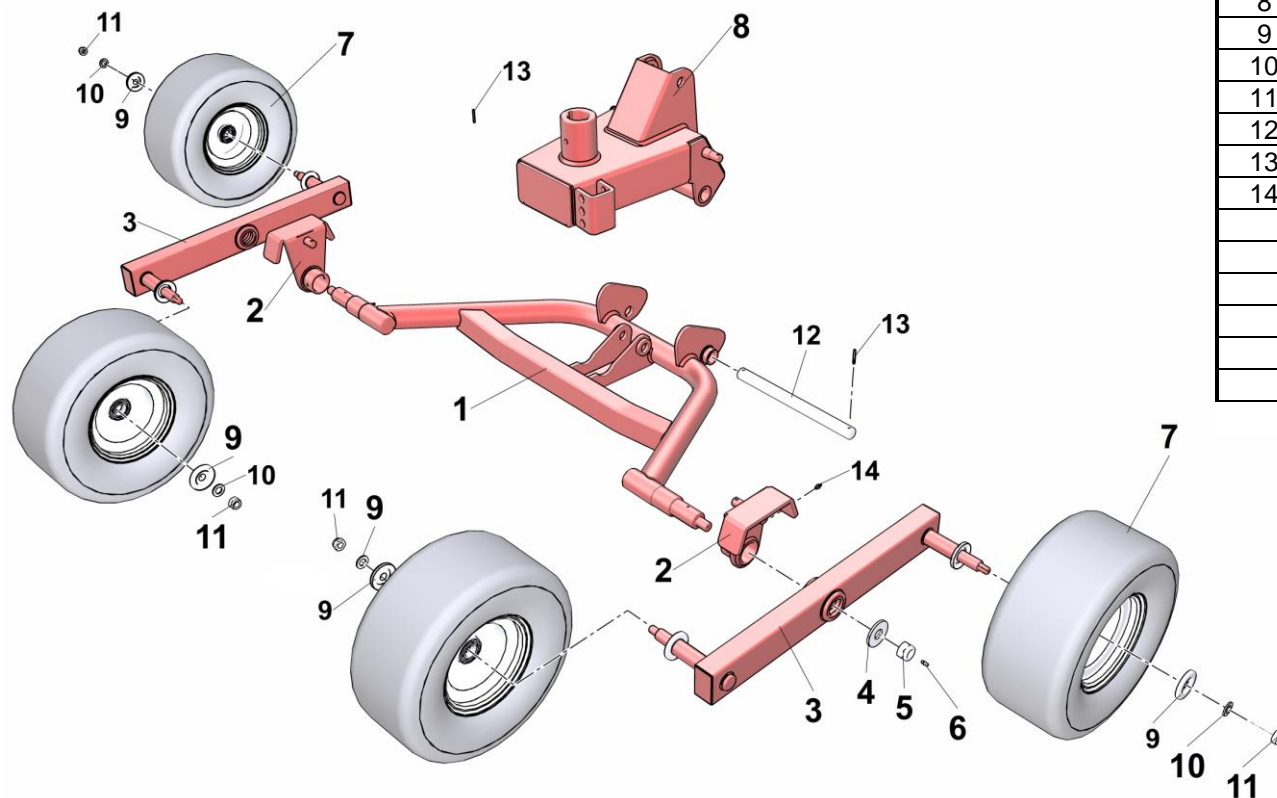







### Assembly 4 - RREVO PT PULL-TYPE

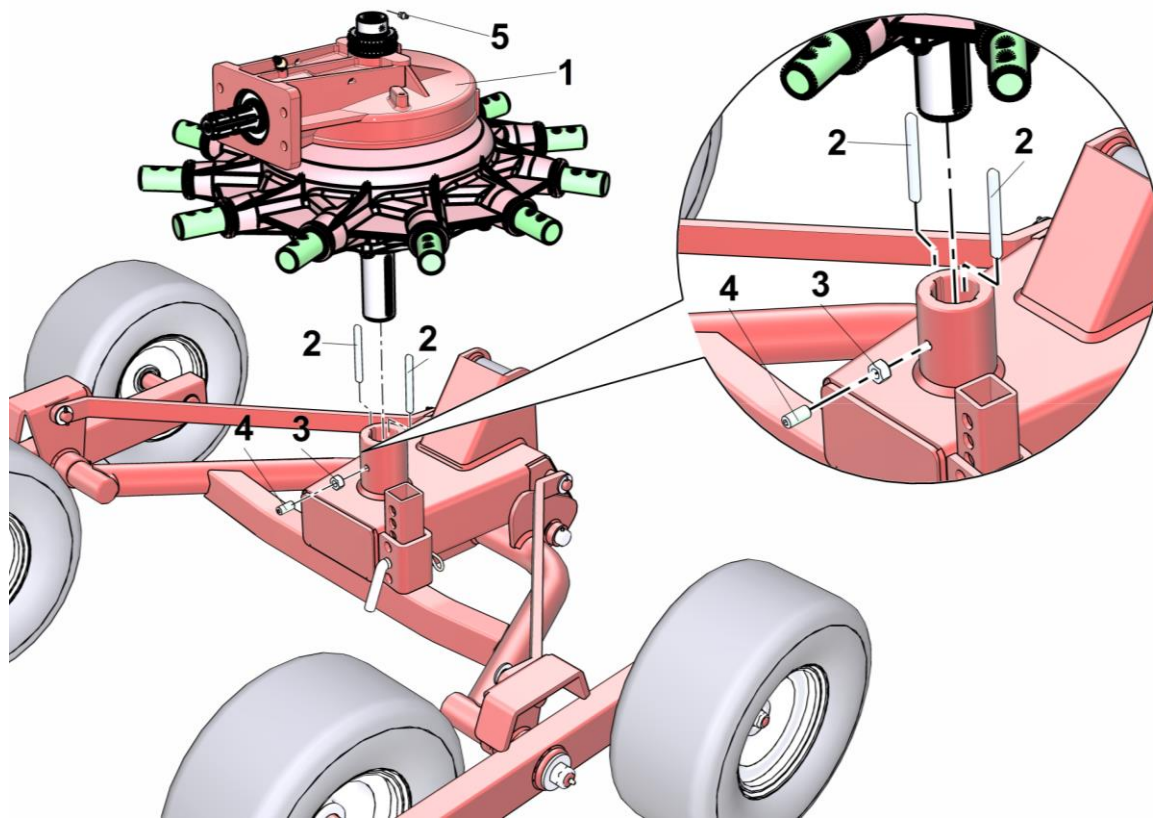

ITEM	CODE	DESCRIPTION
1		GEARBOX RREVO
2	3110029	TAB 10X8X110 A
3	3020332	NUT M14 ZN
4	3011146	GRUB SCREW M14X30
5	3090101	GREASE ZERK M8X1

### Assembly 5 - RREVO PT PULL-TYPE

ITEM	CODE	DESCRIPTION
1		FRAME
2	3011631	H. H. SCREW M14X70 ZN
3	18033390	SPACER Ø28 L.20
4	18033315	PLATE FIX. ROTOR
5	3020363	NUT B.M14 ZN

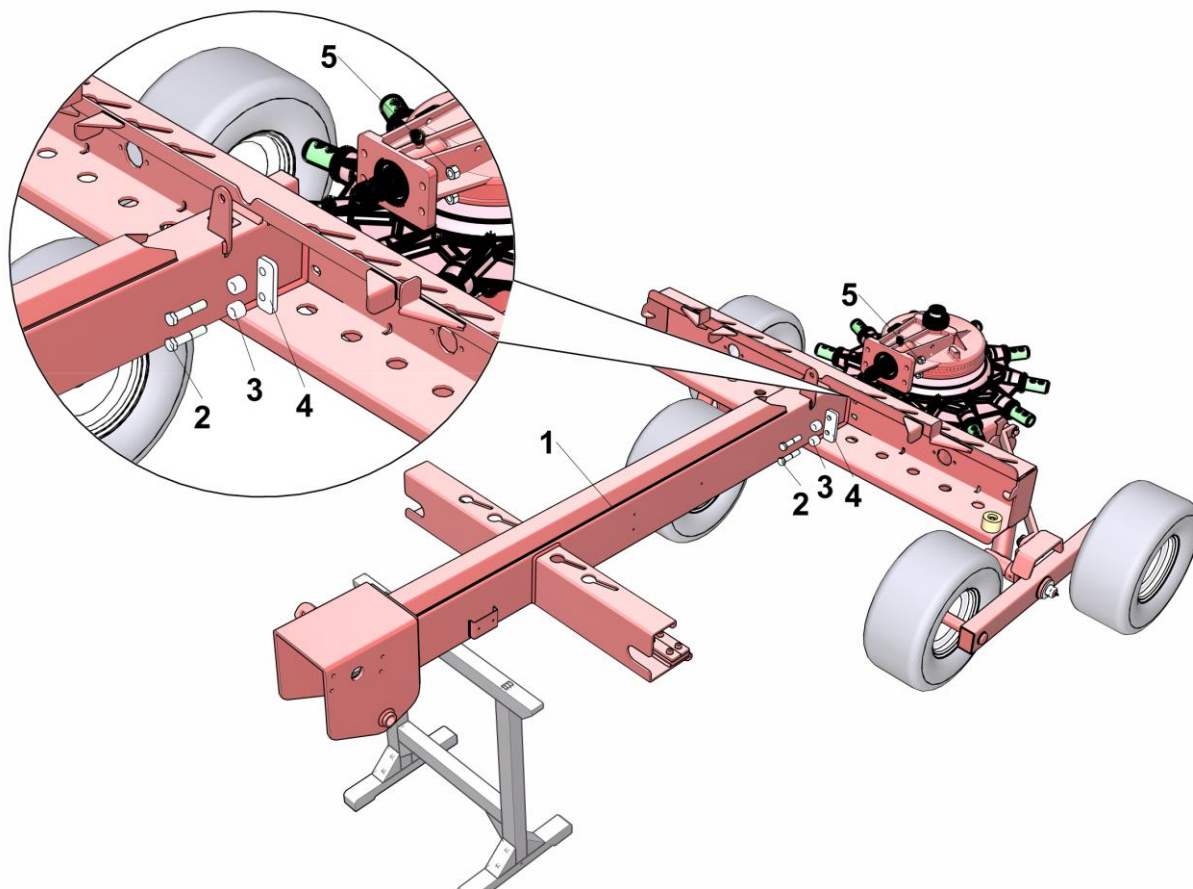

### Assembly 6 - RREVO PT PULL-TYPE

ITEM	CODE	DESCRIPTION
1	18032229	PULL BAR
2	18032238	HOLED PIN Ø25 L.250
3	3080102	ELASTIC PIN 6X36
4	18032226	ROD
5	3011202	H. H. SCREW M14X60 ZN
6	3020203	SELF LOCKING NUT M14
7	18032228	HOLED PIN Ø25 L.190
8	3030186	WASHER 56X26X5 ZN
9	18032227	COUPLING HITCH

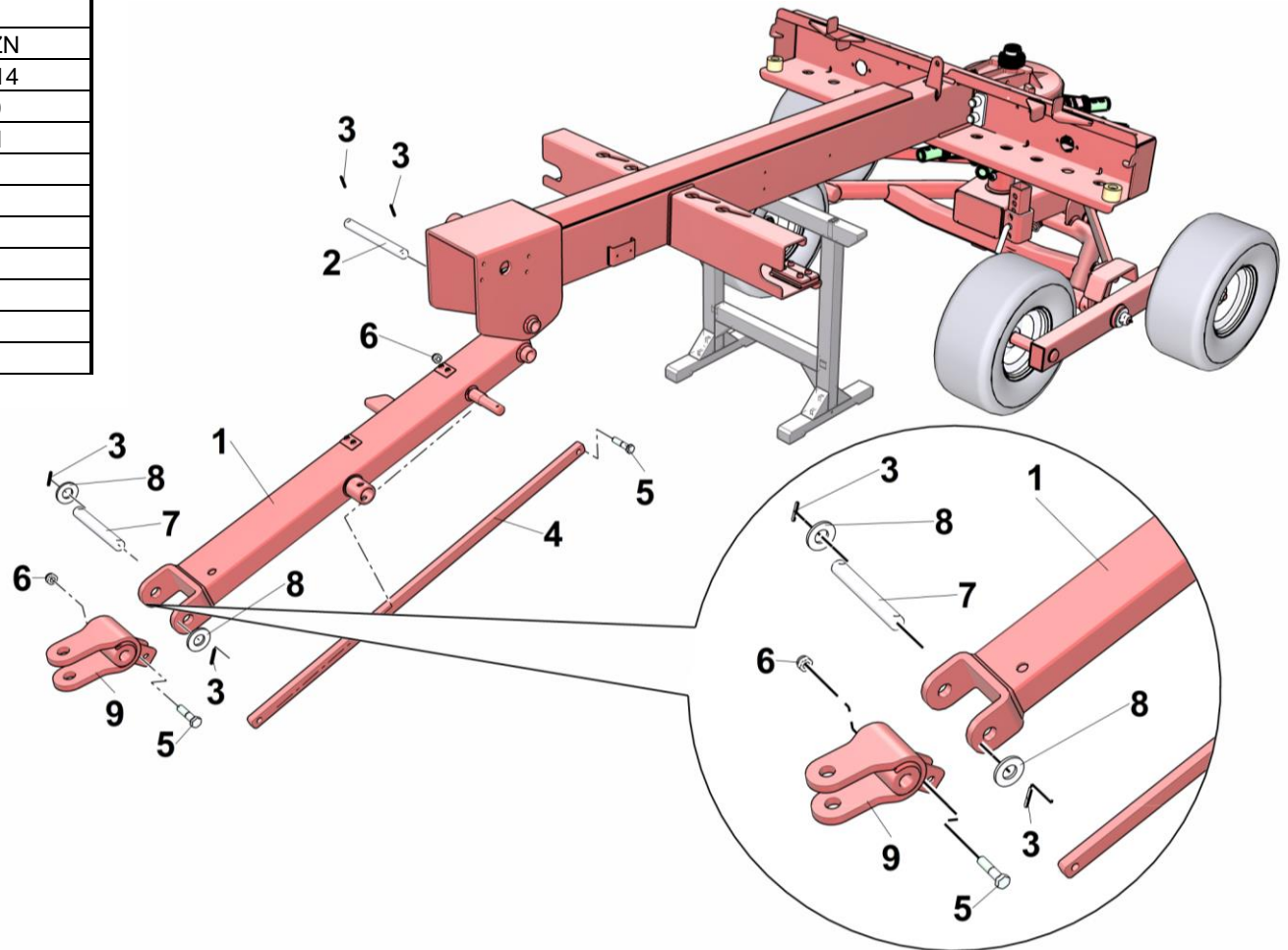



### Assembly 7 - RREVO PT PULL-TYPE

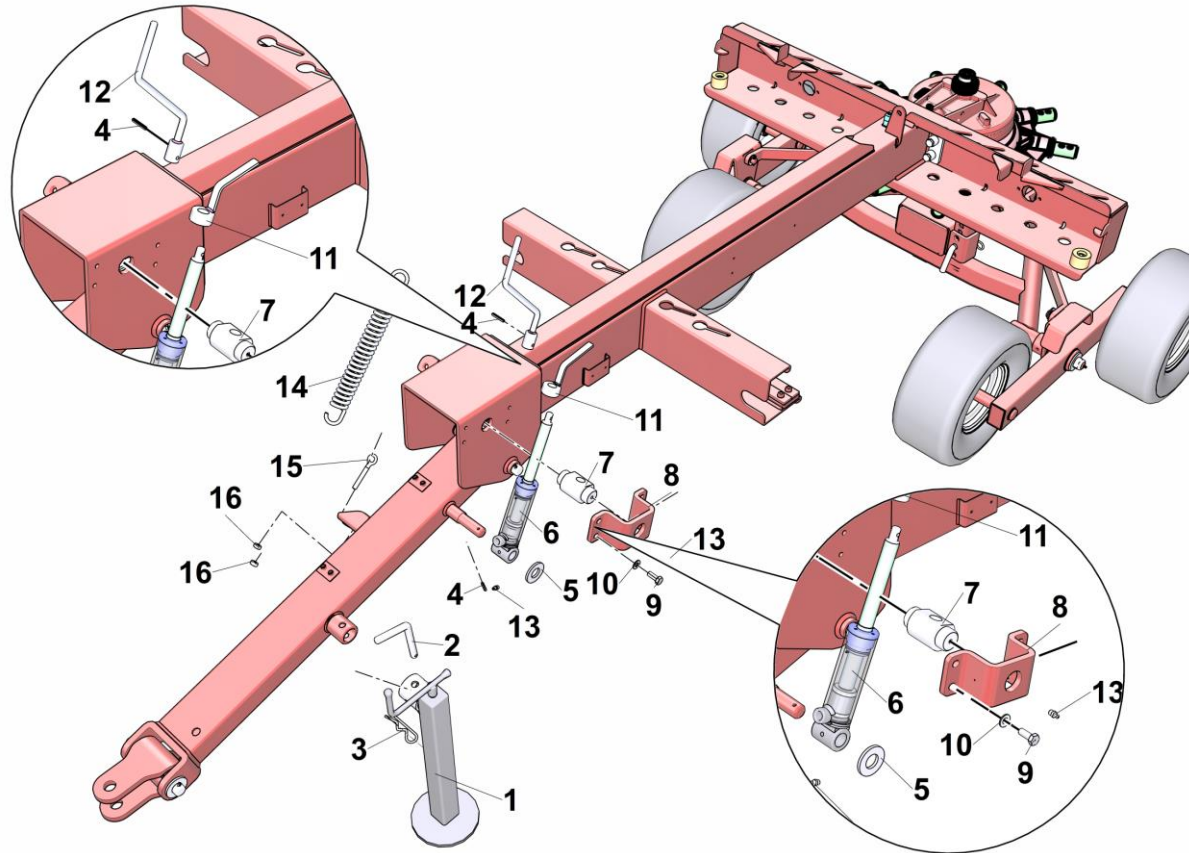

ITEM	CODE	DESCRIPTION
1	18032774	BEARING FOOT
2	18033195	HANDLE PIN
3	3040202	R COTTER PIN
4	3080102	ELASTIC PIN 6X36
5	3030186	WASHER 56X26X5 ZN
6	18032236	HYDRAULIC CYLINDER
7	18032237	SPLIT NUT
8	18032235	CYLINDER BRACKET
9	3011211	H. H. SCREW M10X25 ZN
10	3030159	WASHER M10 ZN
11	18032234	LOCKING RING NUT
12	18032233	REGOLATING SCREW
13	3090101	GREASE ZERK M8X1
14	11010501	SPRING
15	3220201	TENSIONER RING
16	3020328	NUT M10 ZN

### Assembly 8 - RREVO PT PULL-TYPE

ITEM	CODE	DESCRIPTION
1	3011616	H. H. SCREW M8X60 ZN
2	18032286	SPRING STOP
3	3020209	SELF LOCKING NUT M8
4	11010537	SPRING
5	3010780	H. H. SCREW M8X30 ZN
6	3030156	WASHER M8 ZN
7	3080204	SAFETY PIN D.10
8	18032273	LEFT PROTECTION
9	18033306	COLLAR
10	18032271	BUSH
11	3011616	H. H. SCREW M8X60 ZN

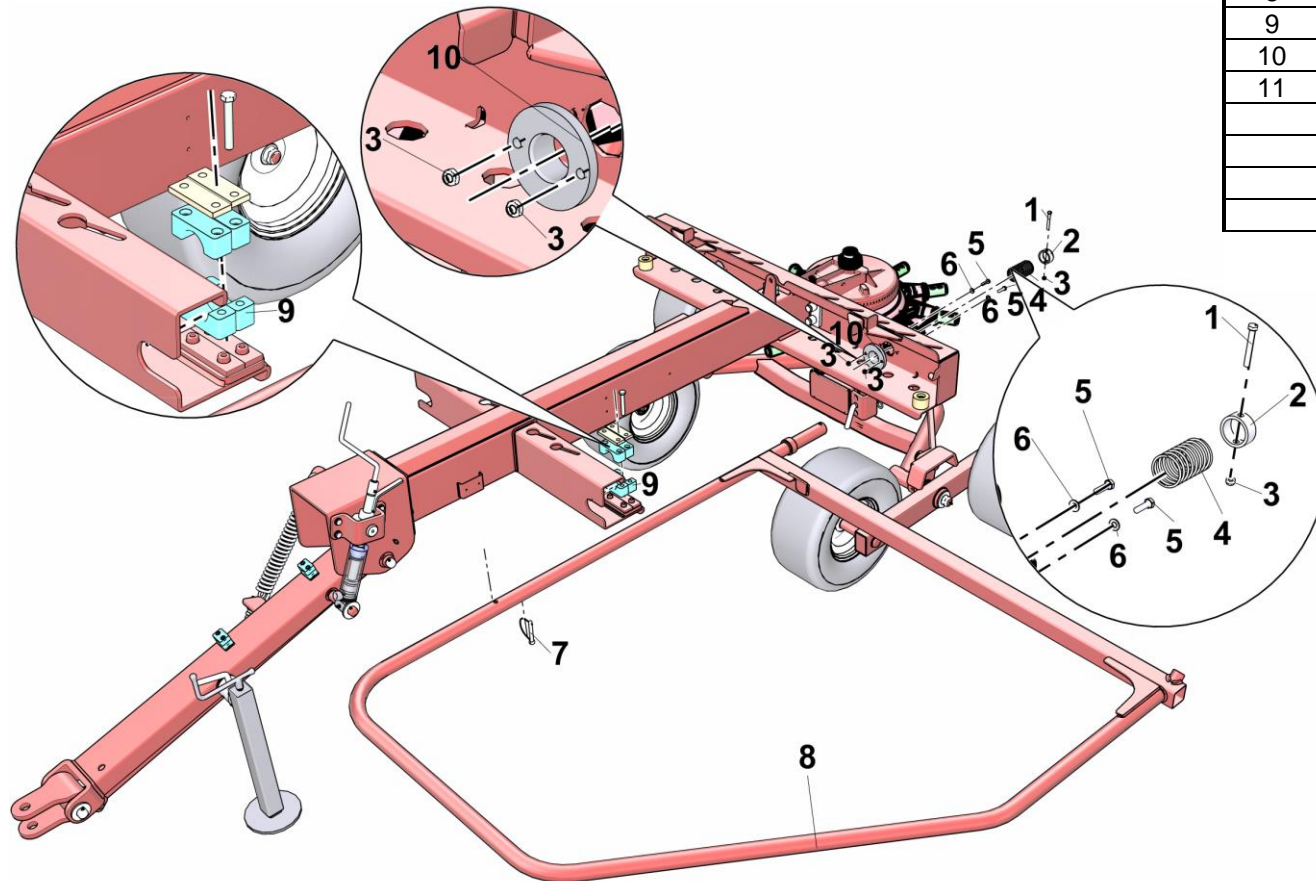





### Assembly 10 - RREVO PT PULL-TYPE

ITEM	CODE	DESCRIPTION
1	18033312	COMPLETE DEFLECTOR
2	3010756	H. H. SCREW M10X70 ZN
3	3020201	SELF LOCKING NUT M10
4	18032275	PROTECTION DEFLECTOR
5	3080204	SAFETY PIN D.10
6	18032285	LOCKING PIN
7	18033168	LOCKING RING NUT
8	3140001	KNOB

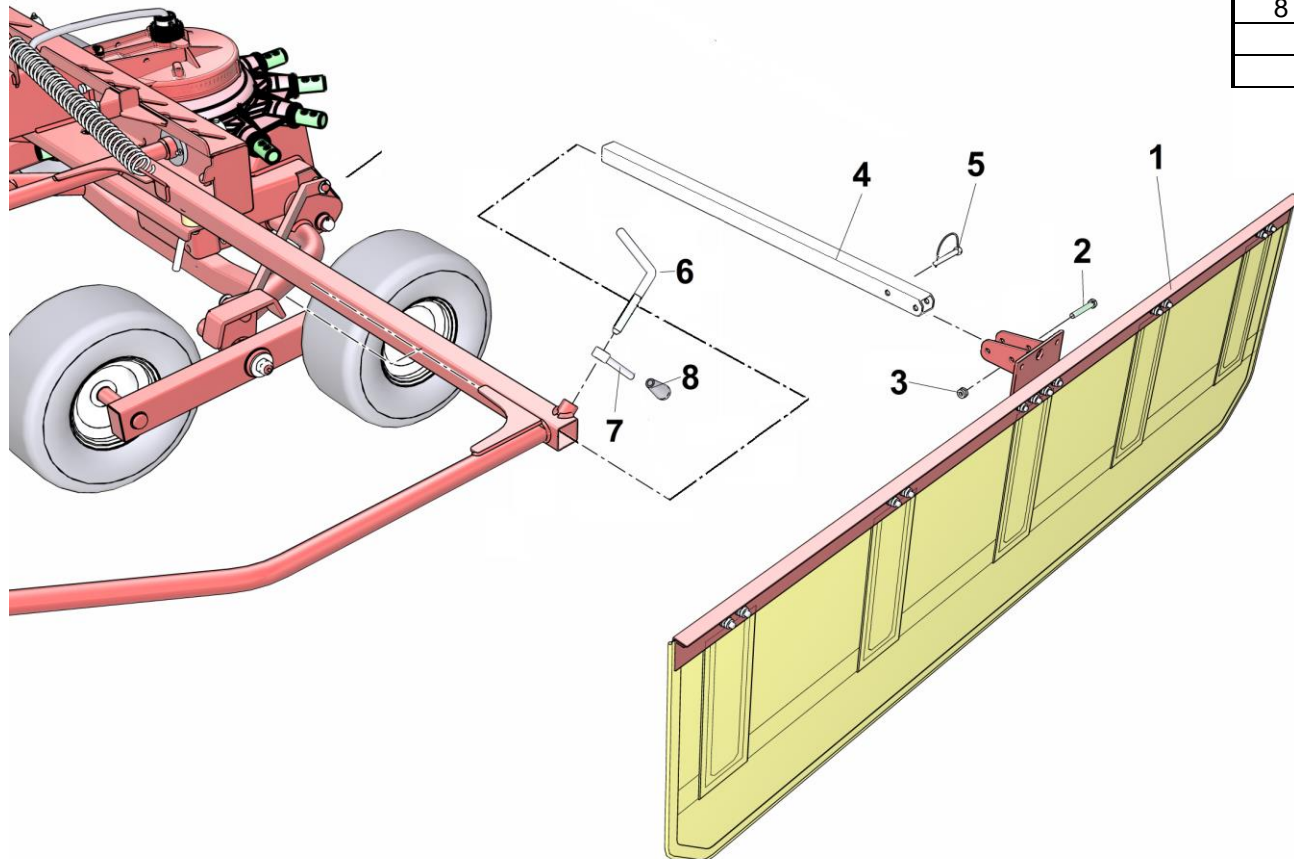

### Assembly 11 - RREVO PT PULL-TYPE

ITEM	CODE	DESCRIPTION
1	18032279	ARM
2	18032280	ARM-HOLDER
3	3011207	H. H. SCREW M12X60 ZN
4	3020202	SELF LOCKING NUT M12
5	3080202	SAFETY PIN
6	9190013	RUBBER CAP Ø35

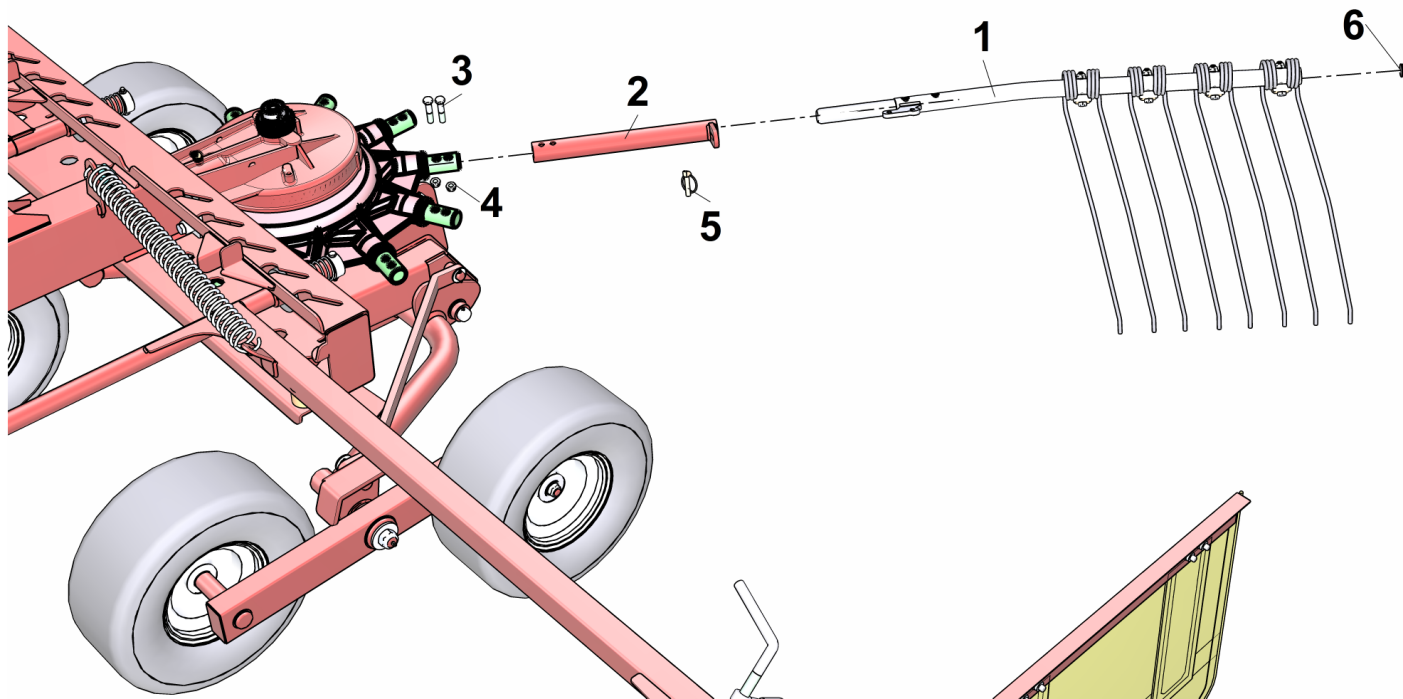

Assembly 12 - RREVO PT PULL-TYPE

ITEM	CODE	DESCRIPTION
1	8020435	CARDAN SHAFT 600 NM L.1160

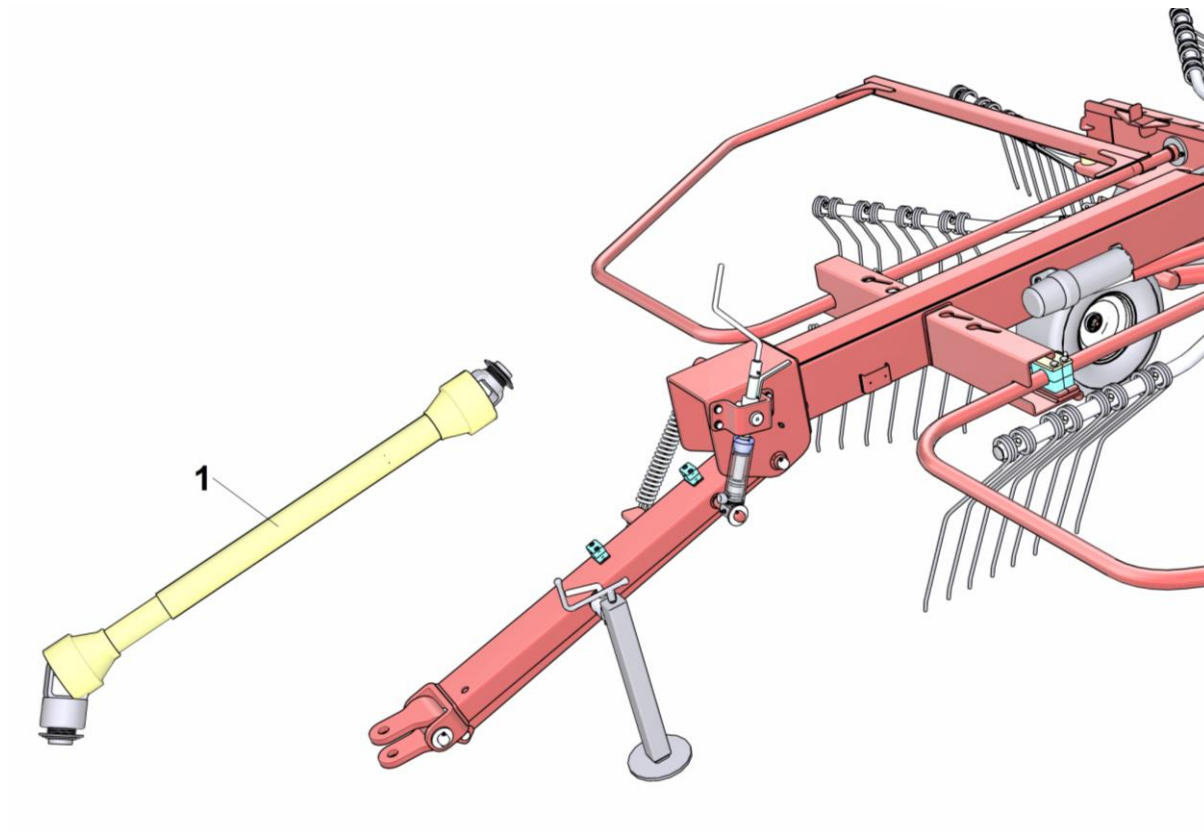

### Assembly 13 - RREVO PT PULL-TYPE

ITEM	CODE	DESCRIPTION
1	12760206	HYDRAULIC HOSE IR ½" L.2000
2	12760207	HYDRAULIC HOSE L.310
3	18032400	HYDRAULIC HOSE L.3650
4	18033216	COLLAR CP3
5	9070105	RUBBER BELLOW
6	9190013	CLAMP

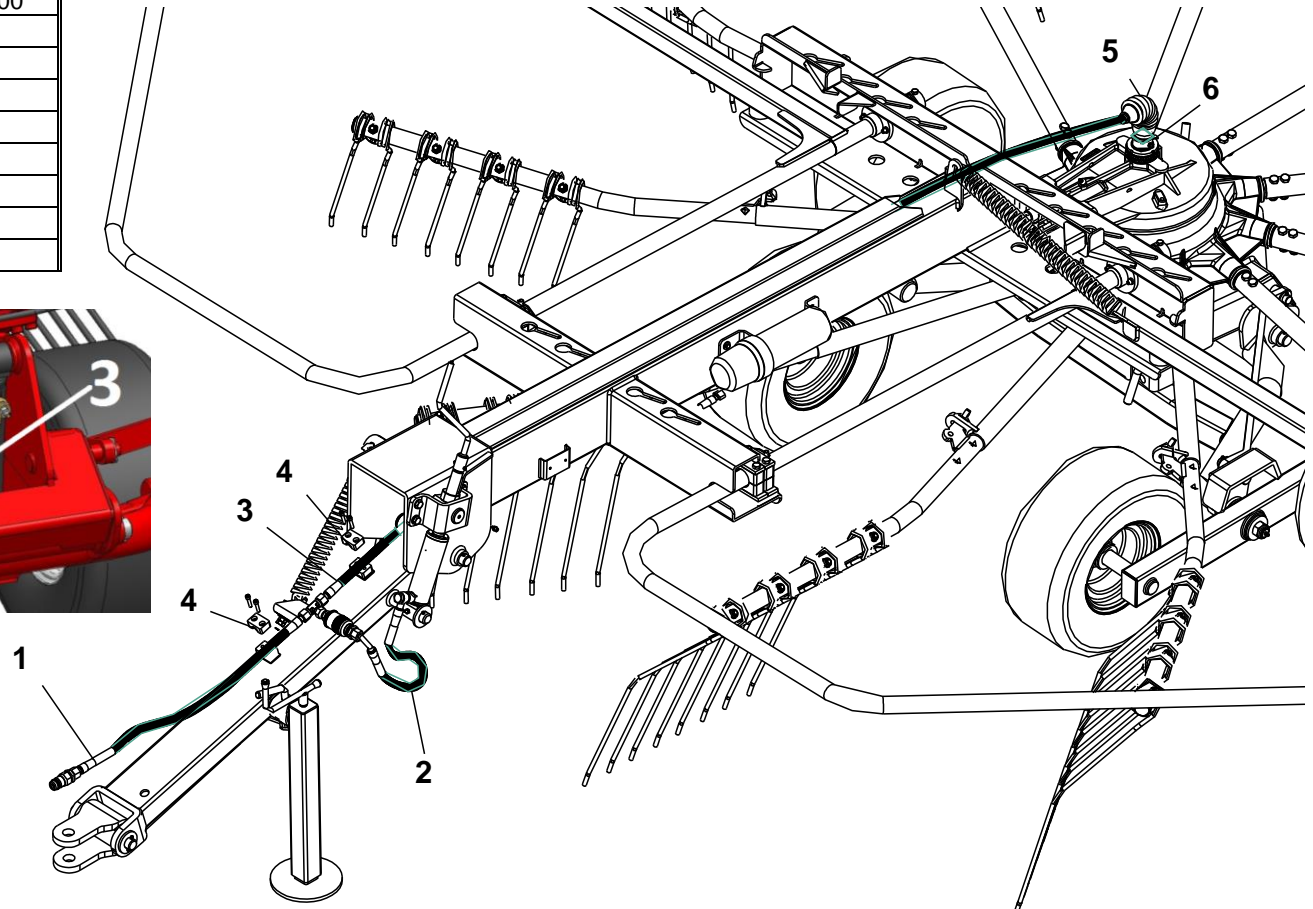
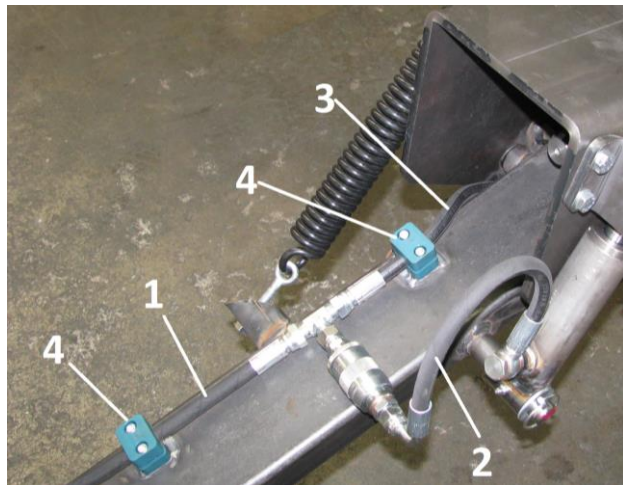
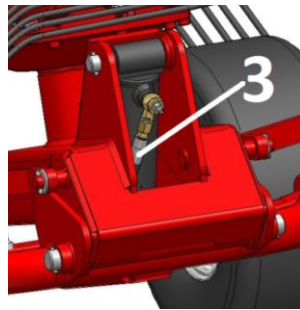



### Assembly 14 - RREVO OPTIONAL

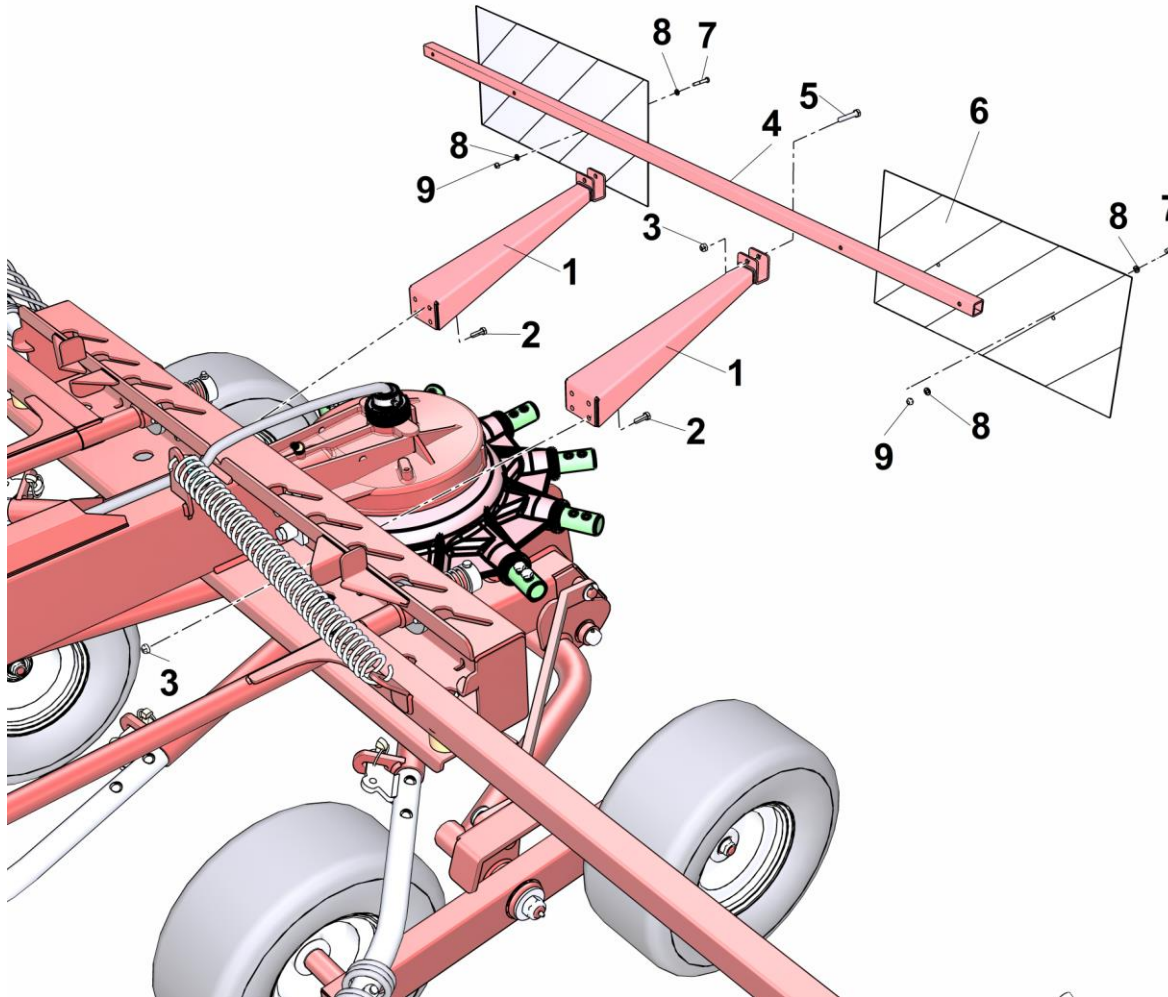

ITEM	CODE	DESCRIPTION
1	18032379	PANEL-HOLDER SUPPORT
2	3011242	H. H. SCREW M8X25 ZN
3	3020209	SELF LOCKING NUT M8
4	18033545	ROD
5	3011258	H. H. SCREW M8X45 ZN
6	12880416	PANEL
7	3011610	H. H. SCREW M6X40 ZN
8	3030158	WASHER M6 ZN
9	3020213	SELF LOCKING NUT M6



### Assembly 15 - RREVO MOUNTED

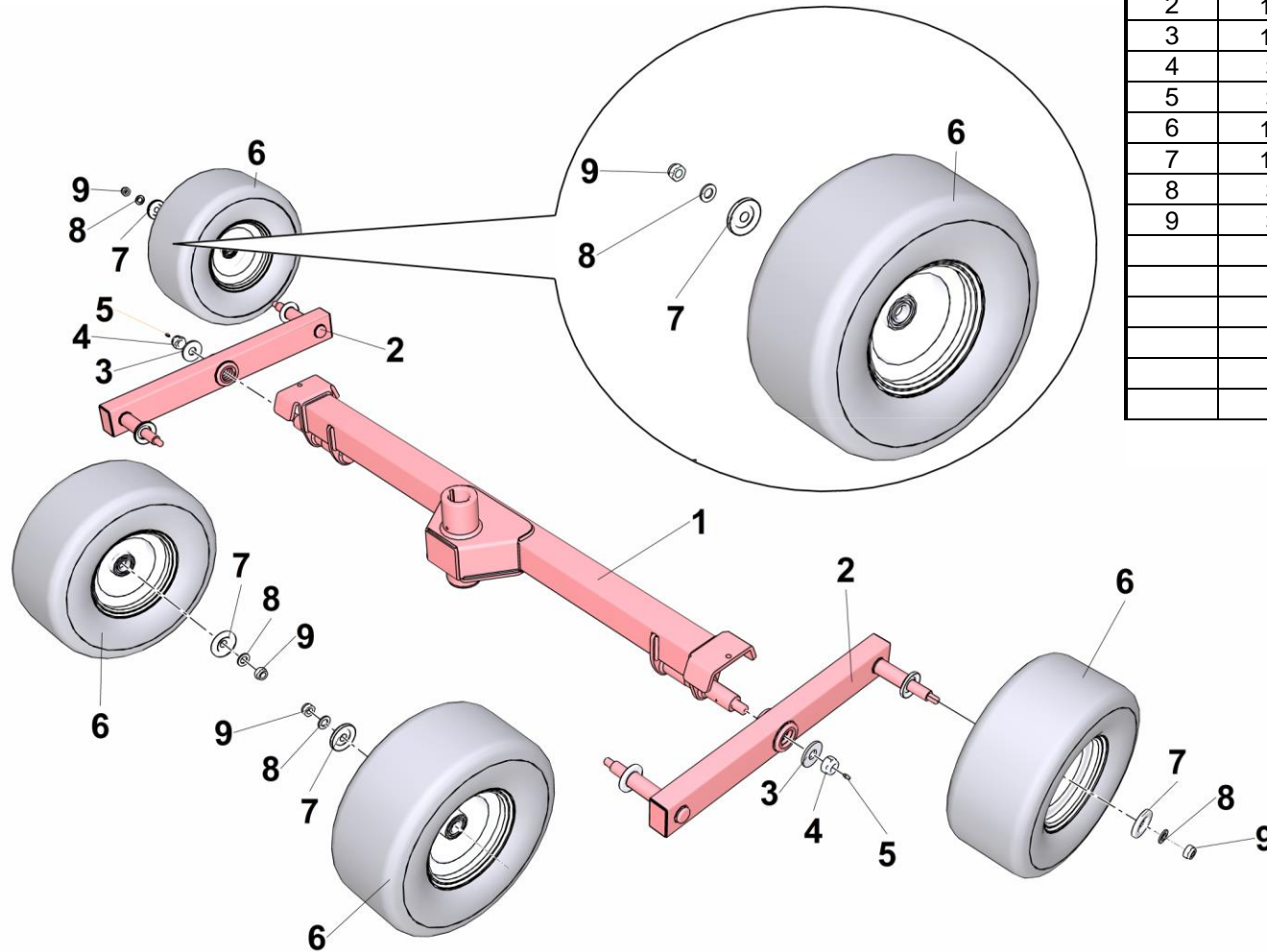

ITEM	CODE	DESCRIPTION
1	18033340	TANDEM FRAME
2	18032239	TANDEM
3	18032281	WASHER 60X23X5
4	3020222	SELF LOCKING NUT M22
5	3090102	GREASE ZERK M6X1
6	12170111	WHEEL
7	12072315	EXTERNAL DUST COVER CUP
8	3030175	WASHER 30X17X3 ZN
9	3020204	SELF LOCKING NUT M16





### Assembly 18 - RREVO MOUNTED

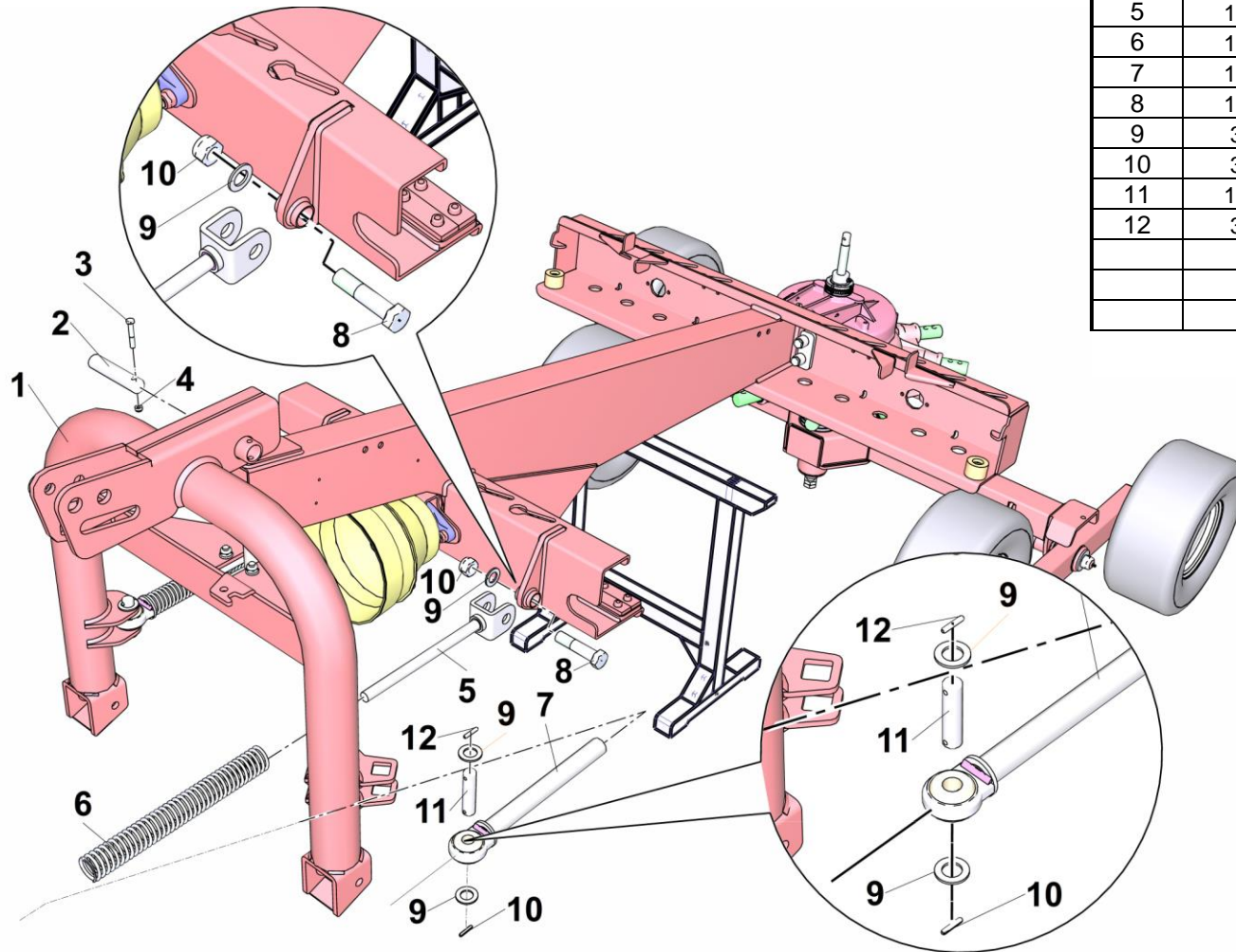

ITEM	CODE	DESCRIPTION
1	18032254	THREE_POINT HITCH
2	18032256	HOLED PIN
3	3011210	H. H. SCREW M8X50
4	3020209	SELF LOCKING NUT M8
5	18032258	CONNECTING ROD WITH BRACKET
6	11010536	SPRING
7	18032259	CONNECTING ROD WITH BALL JOINT
8	18032363	H.H. SCREW
9	3030176	WASHER M22 ZN
10	3020222	SELF LOCKING NUT M22
11	18032362	HOLED PIN Ø22 L.89
12	3080102	ELASTIC PIN 6X36

### Assembly 19 - RREVO MOUNTED

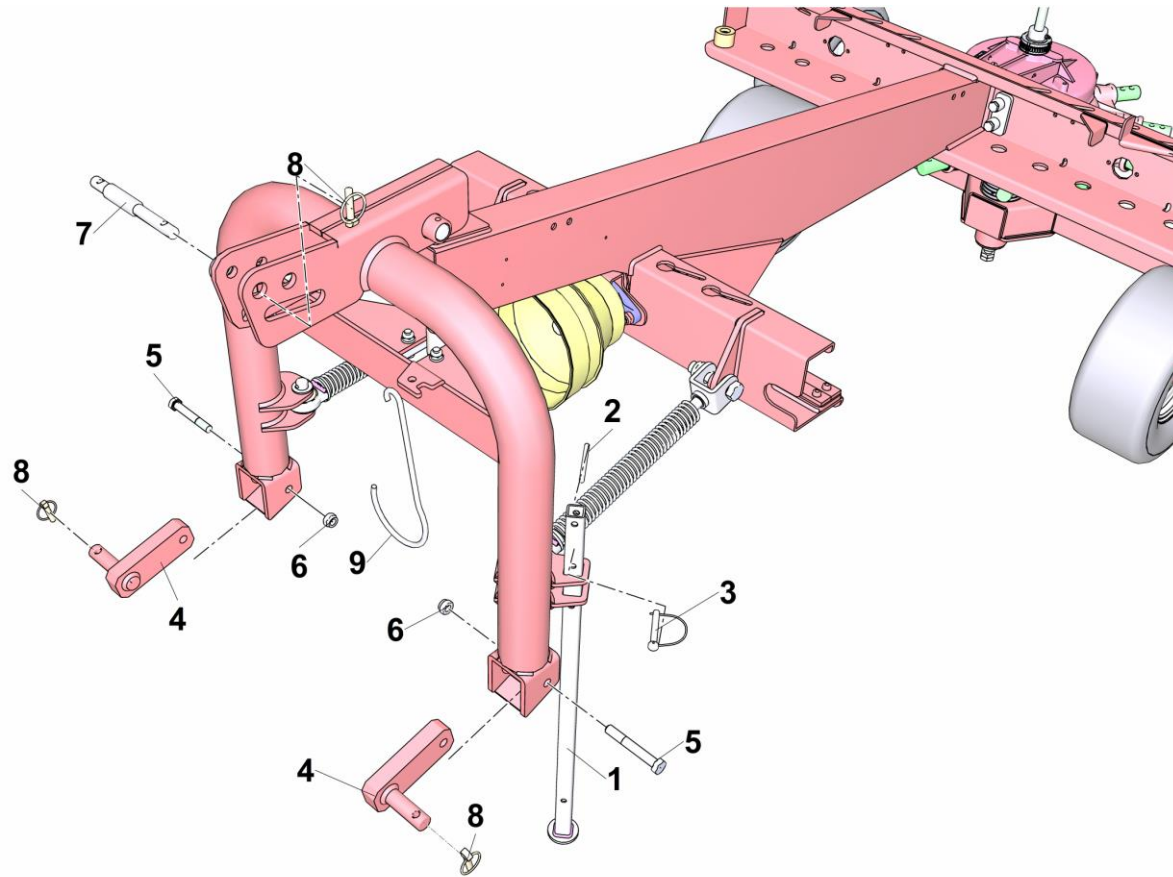

ITEM	CODE	DESCRIPTION
1	18032260	BEARING FOOT
2	3040117	R COTTER PIN 8X80
3	3080204	SAFETY PIN D.10
4	18031422	PIN WITH BRACKET
5	3010408	H. H. SCREW M16X110 ZN
6	3020204	SELF LOCKING NUT M16
7	12310115	3-POINT PIN
8	3080202	SAFETY PIN
9	18032512	CARDAN HOOK



### Assembly 20 - RREVO MOUNTED

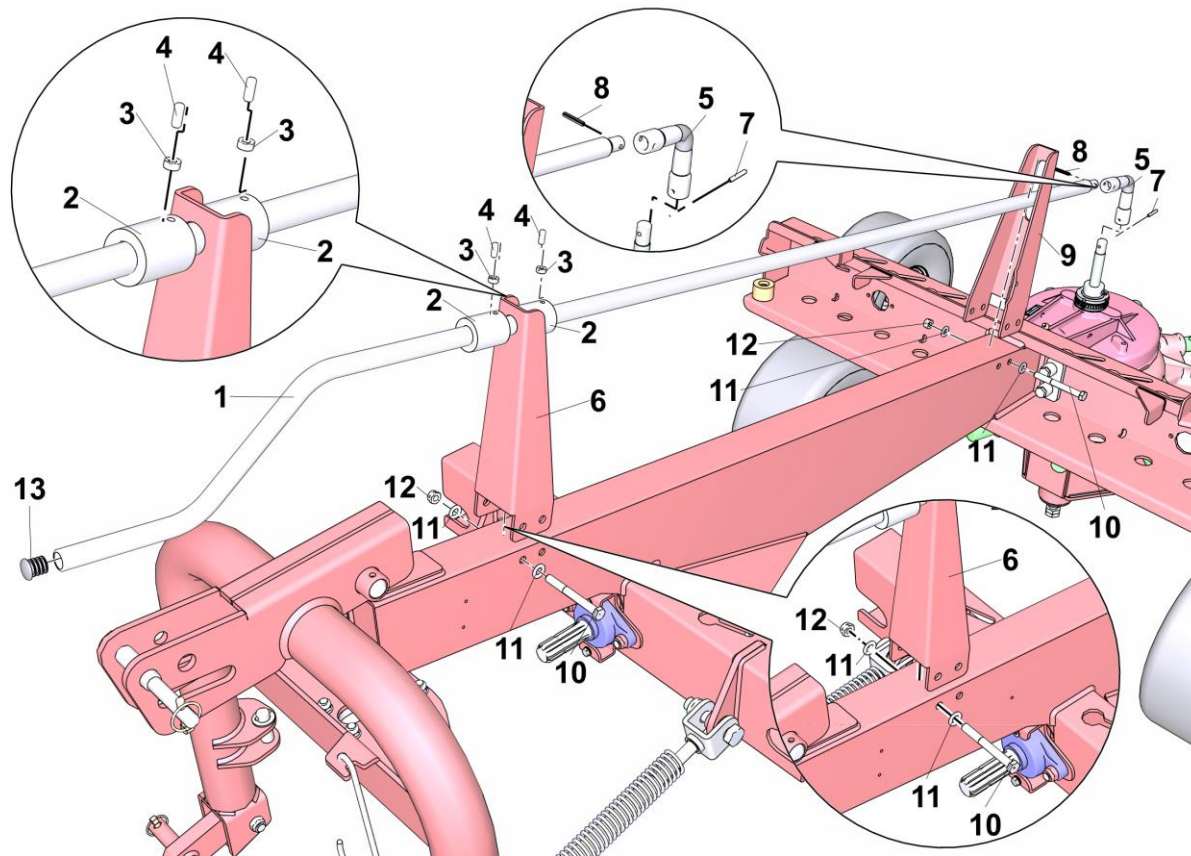

ITEM	CODE	DESCRIPTION
1	18032261	AXLE
2	18032361	STOP
3	3020329	NUT M8 ZN
4	3050107	GRUB SCREW M8X20
5	18033975	ARTICULED JOINT
6	18032267	FRONT STRUT
7	3080102	ELASTIC PIN 6X36
8	3080102	ELASTIC PIN 6X36
9	18032263	REAR STRUT
10	3011313	H. H. SCREW M12X110 ZN
11	3030162	WASHER M12 ZN
12	3020202	SELF LOCKING NUT M12
13	9190012	RUBBER CAP

### Assembly 21 - RREVO MOUNTED

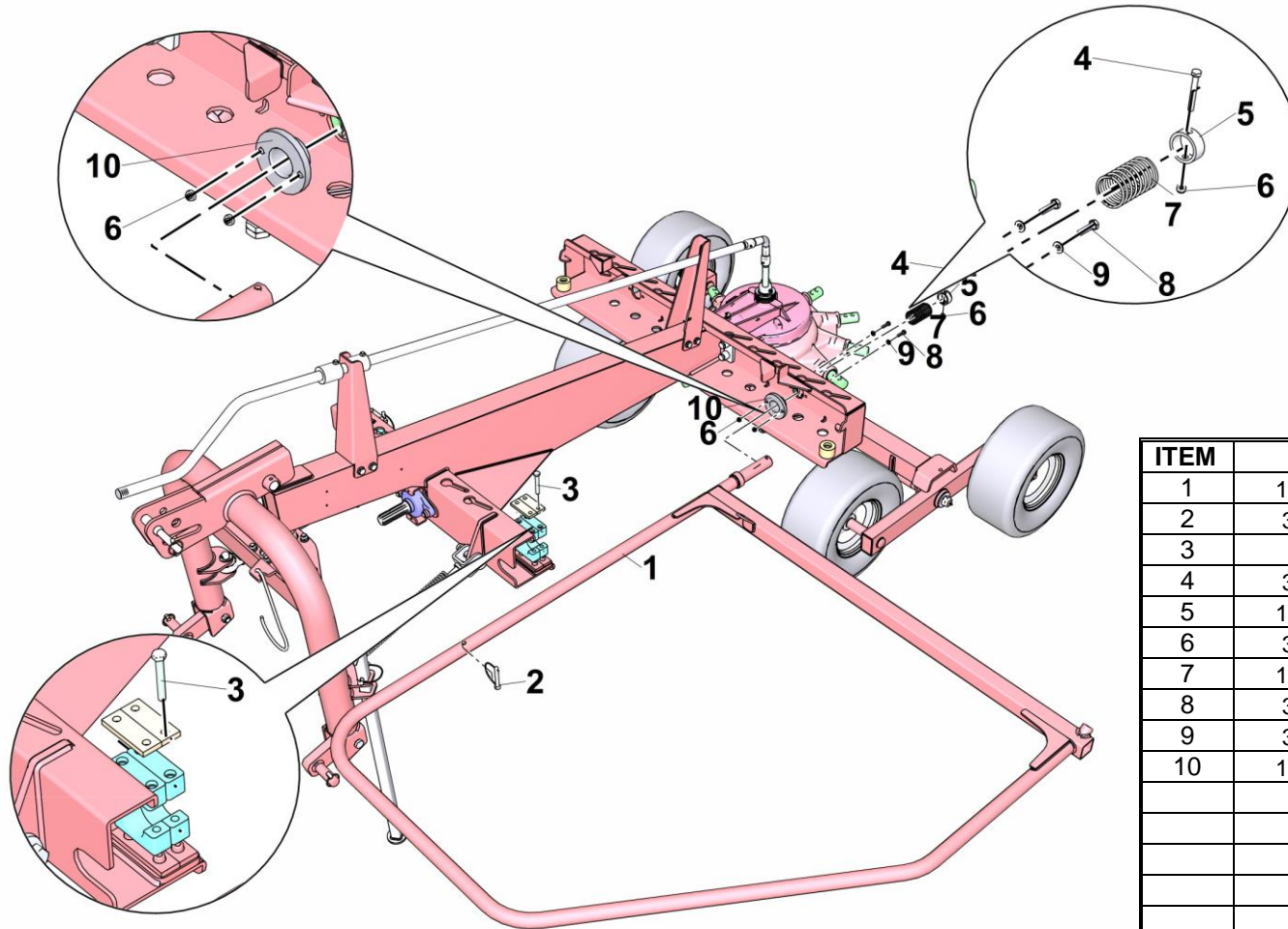

ITEM	CODE	DESCRIPTION
1	18032273	LEFT PROTECTION
2	3080204	SAFETY PIN D.10
3		H. H. SCREW M10X70
4	3011616	H. H. SCREW M8X60 ZN
5	18032286	SPRING STOP
6	3020209	SELF LOCKING NUT M8
7	11010537	SPRING
8	3010780	H. H. SCREW M8X30 ZN
9	3030156	WASHER M8 ZN
10	18032271	BUSH

### Assembly 22 - RREVO MOUNTED

ITEM	CODE	DESCRIPTION
1	3011221	H. H. SCREW M8X16
2	3030156	WASHER M8 ZN
3	18033339	PROTECTION GUARD
4	9080022	MANUAL-HOLDER
5	3030160	WASHER M6 EXL ZN
6	3011617	H. H. SCREW M6X20 ZN
7	11010534	SPRING

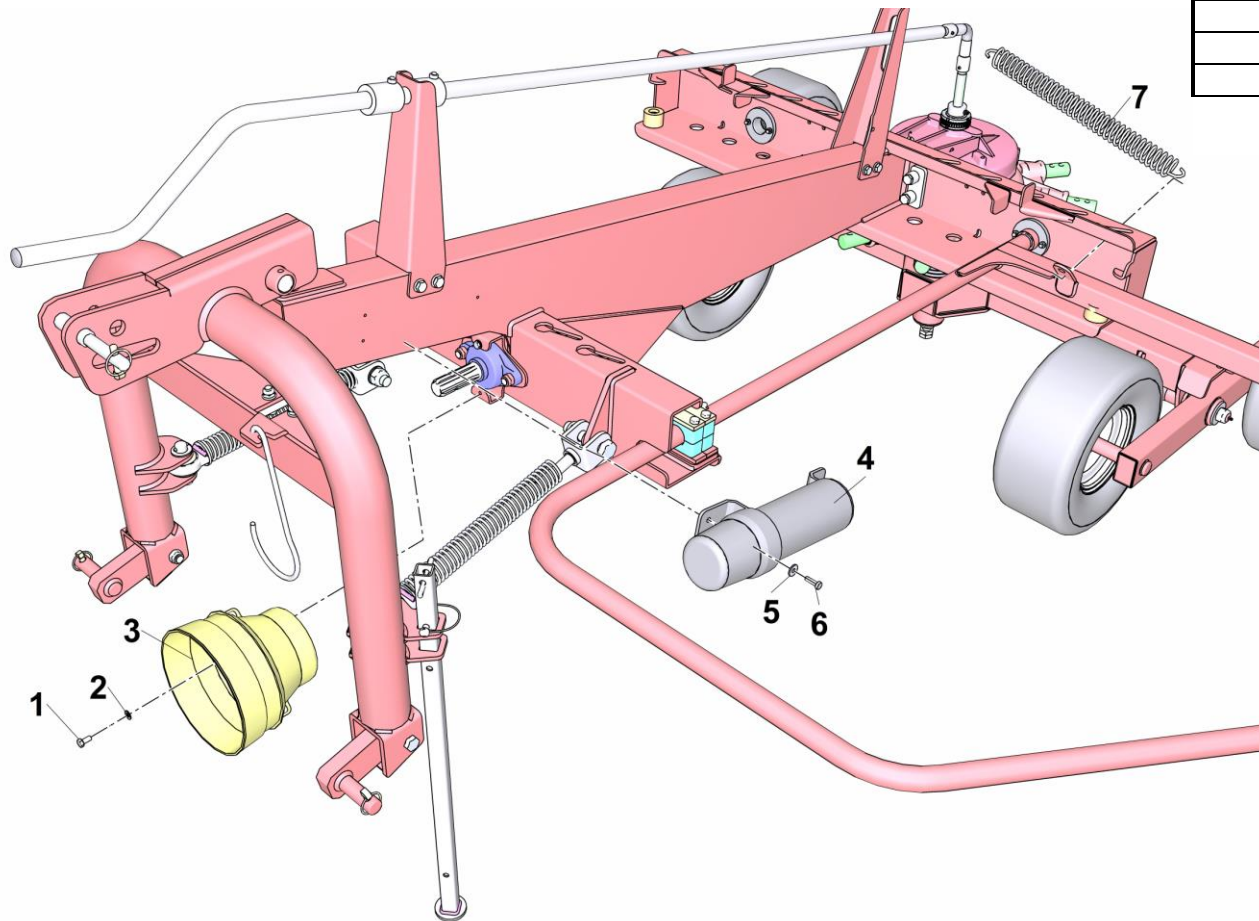

### Assembly 23 - RREVO MOUNTED

ITEM	CODE	DESCRIPTION
1	18032270	RIGHT PROTECTION
2	3080204	SAFETY PIN D.10
3		
4	18032271	BUSH
5	3020209	SELF LOCKING NUT M8
6	3030156	WASHER M8 ZN
7	3010780	H. H. SCREW M8X30 ZN
8	11010537	SPRING
9	3011616	H. H. SCREW M8X60 ZN
10	18032286	SPRING STOP

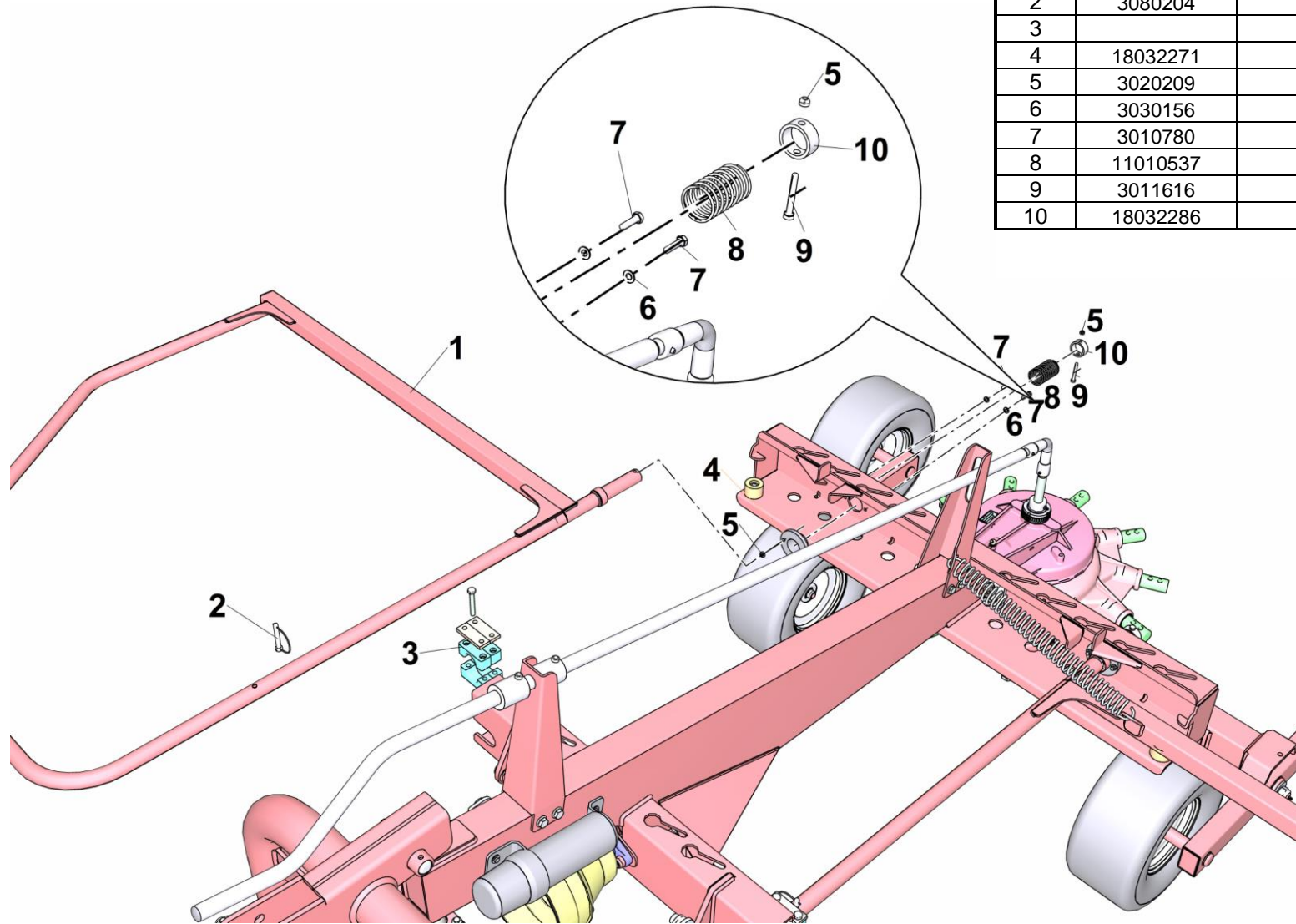



### Assembly 24 - RREVO MOUNTED

ITEM	CODE	DESCRIPTION
1	18033312	COMPLETE DEFLECTOR
2	3010756	H. H. SCREW M10X70 ZN
3	3020201	SELF LOCKING NUT M10
4	18032275	DEFLECTOR HOLDER
5	18032285	LOCKING PIN
6	18033168	LOCKING RING NUT
7	3140001	KNOB
8	3080204	SAFETY PIN D.10

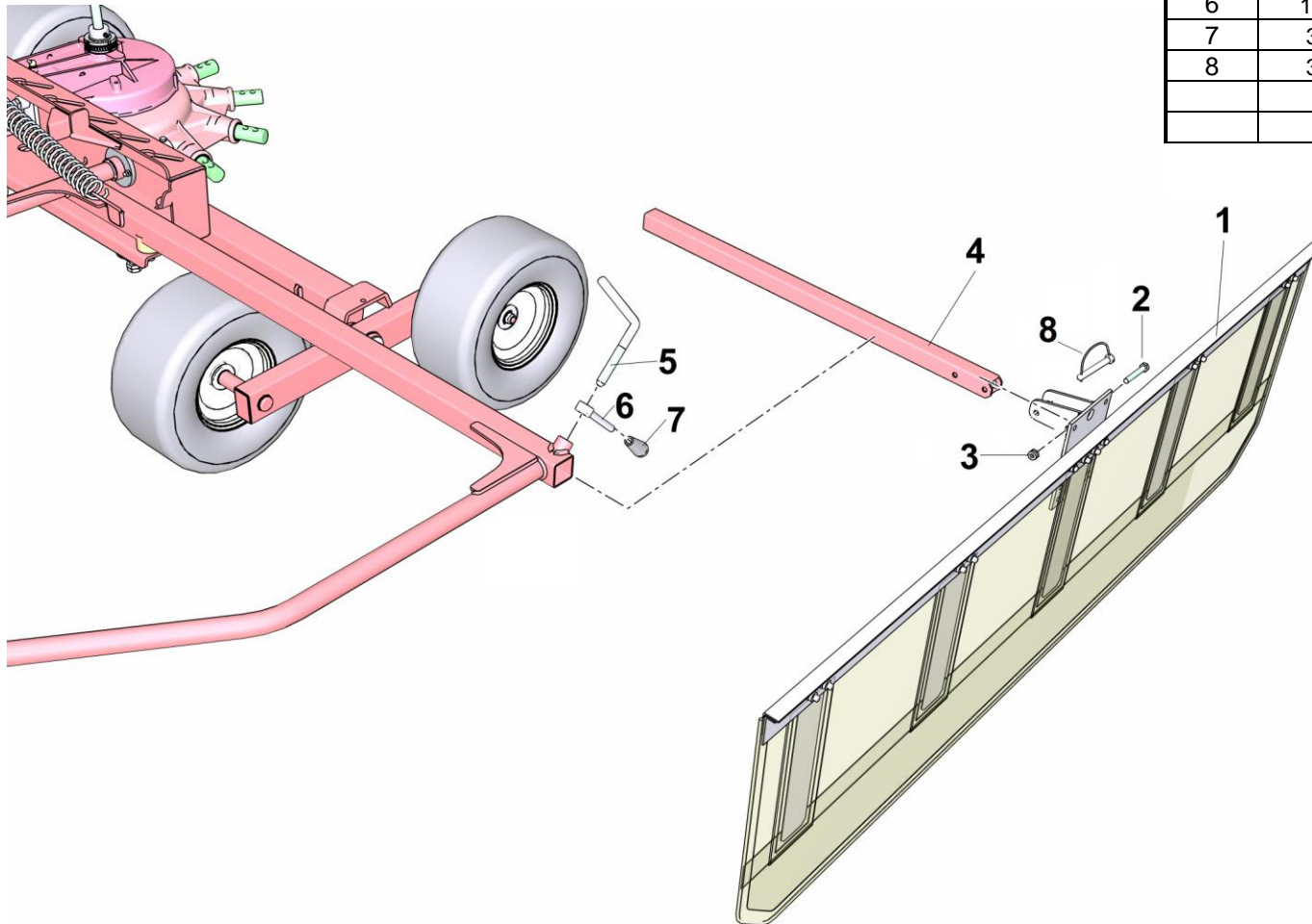



### Assembly 25 - RREVO MOUNTED

ITEM	CODE	DESCRIPTION
1	18032279	ARM
2	18032280	ARM-HOLDER
3	3080202	SAFETY PIN
4	3011207	H. H. SCREW M12X60 ZN
5	3020202	SELF LOCKING NUT M12
6	9190013	RUBBER CAP

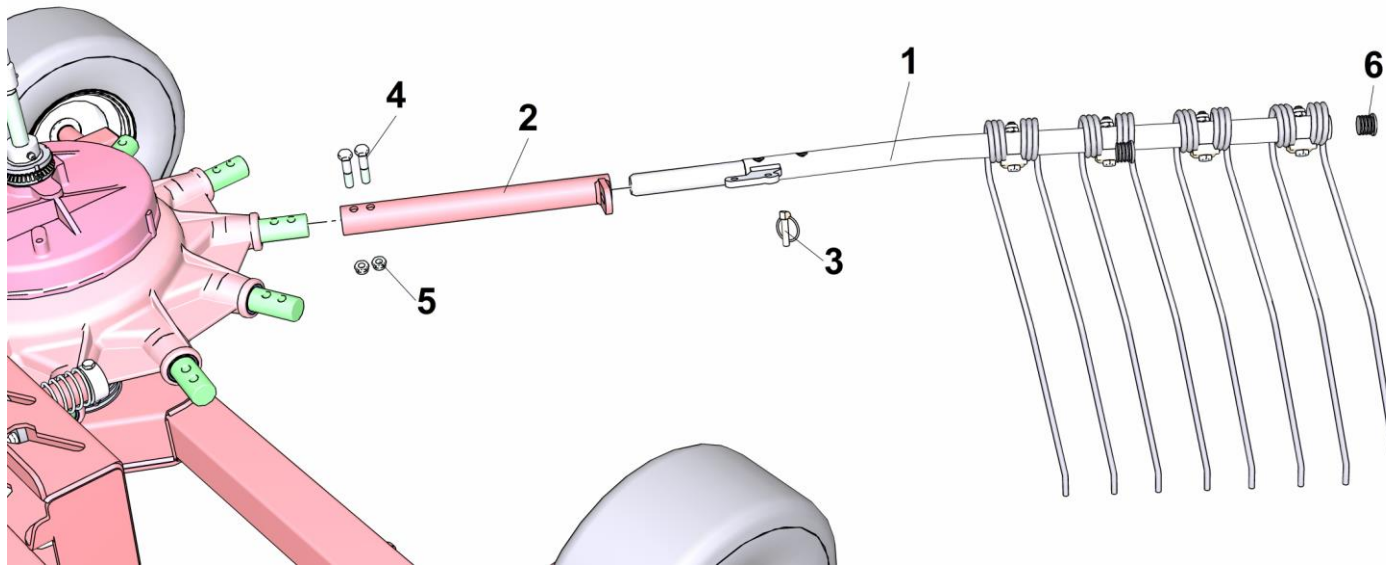

**Assembly 26 - RREVO MOUNTED**

ITEM	CODE	DESCRIPTION
1	8020443	CARDAN SHAFT 2FIL 600 NM

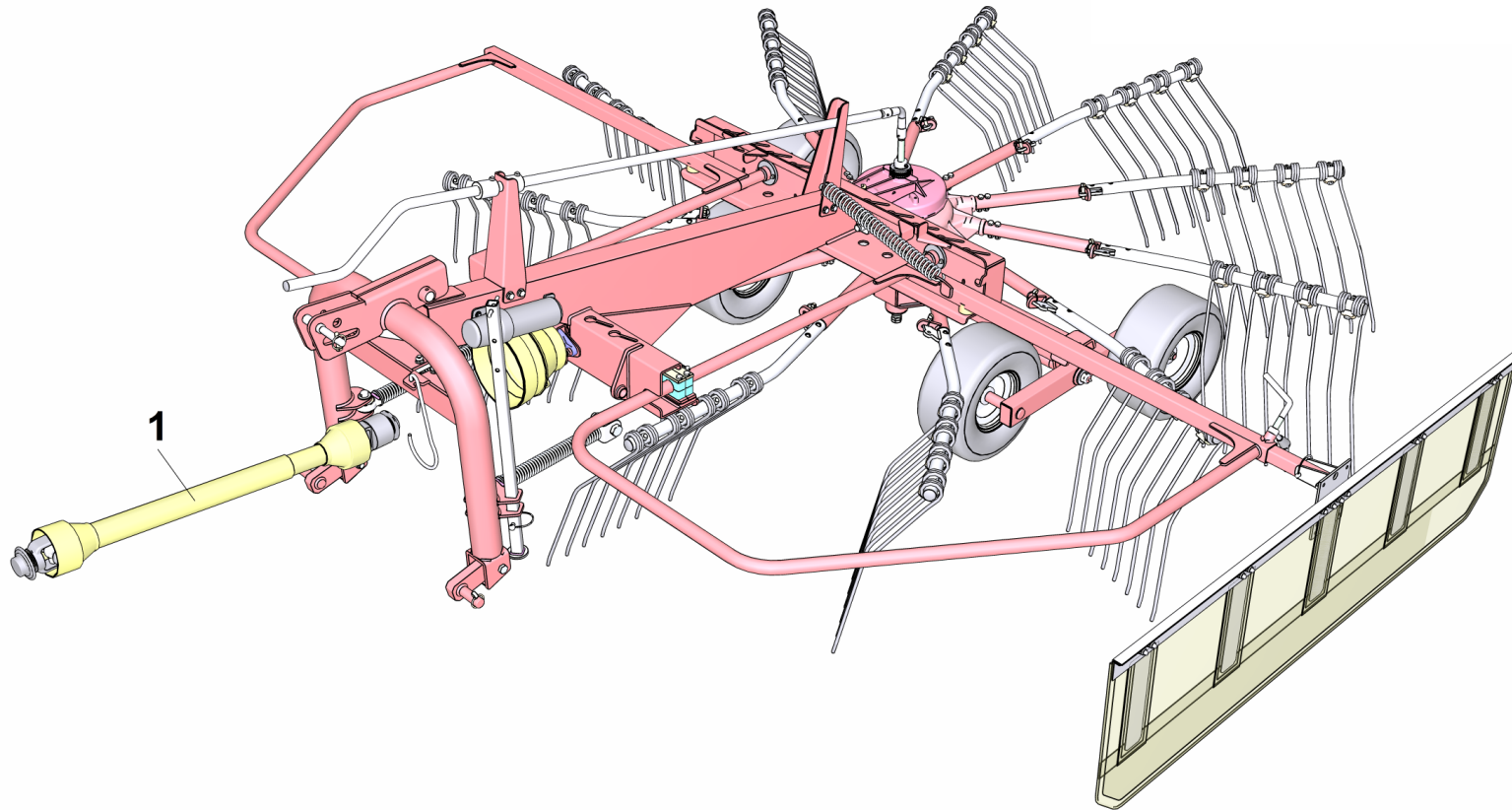

### Assembly 27 - RREVO MOUNTED

ITEM	CODE	DESCRIPTION
1	18030876	WHEEL WITH VERTICAL SUPPORT
2	18033034	SECTOR
3	18033033	ARM
4	3170119	U BOLT M12
5	3030162	WASHER M12 ZN
6	3020333	NUT M12 ZN
7	3011612	H. H. SCREW M8X70 ZN
8	3011612	H. H. SCREW M8X70 ZN
9	3020329	NUT M8 ZN
10	18032340	PIN
11	3040202	R COTTER PIN 5X100
12	3090101	GREASE ZERK M8X1

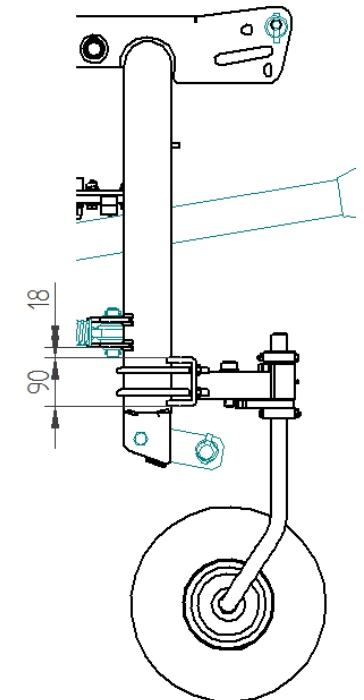
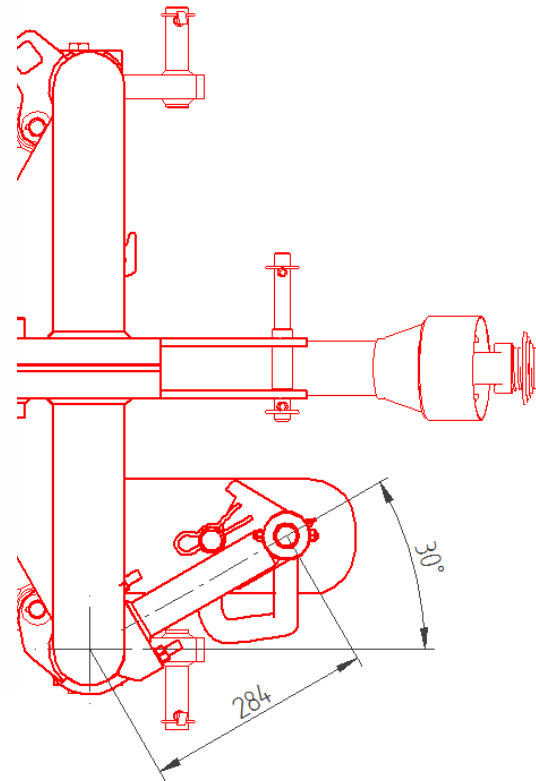
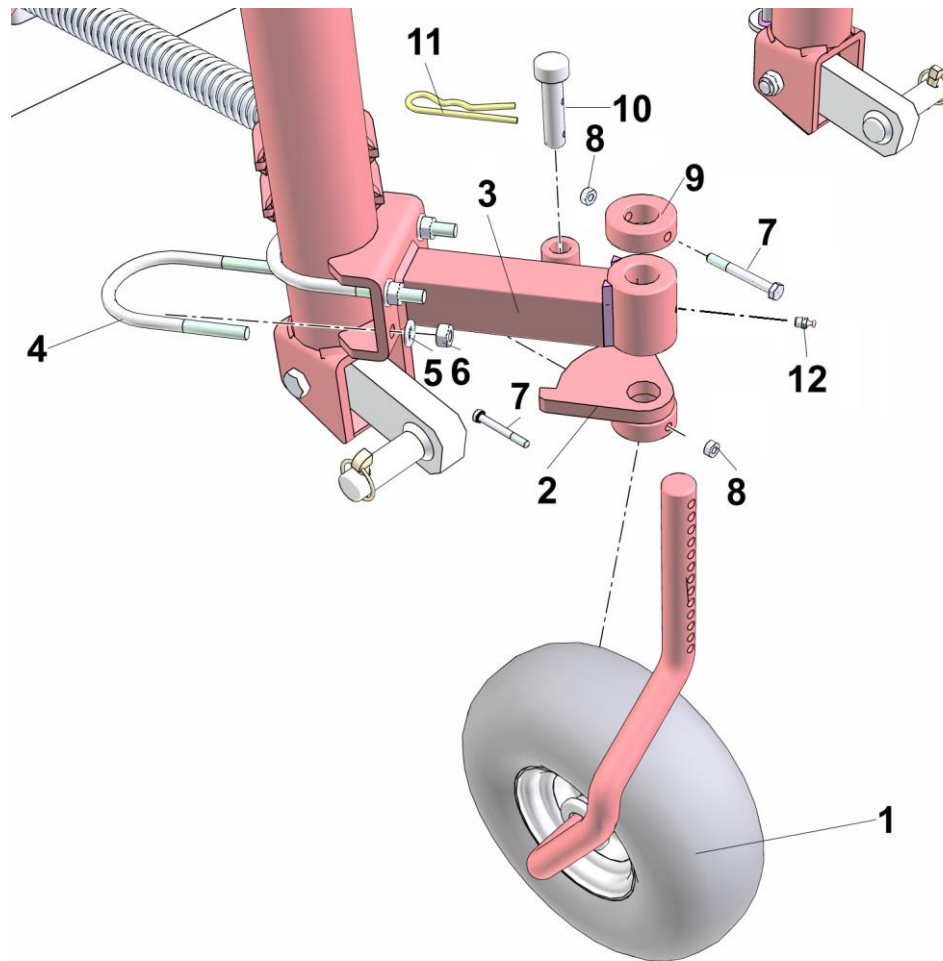

1 Vista di alta qualità - Vista principale - A43244 CON RUOTII





---

A series of 20 horizontal dotted lines for writing, spaced evenly across the page.





*Service Parts*

**RR EVO 3P - PT**

rev.5a - 01/2017





TABLE 1 – MOUNTED

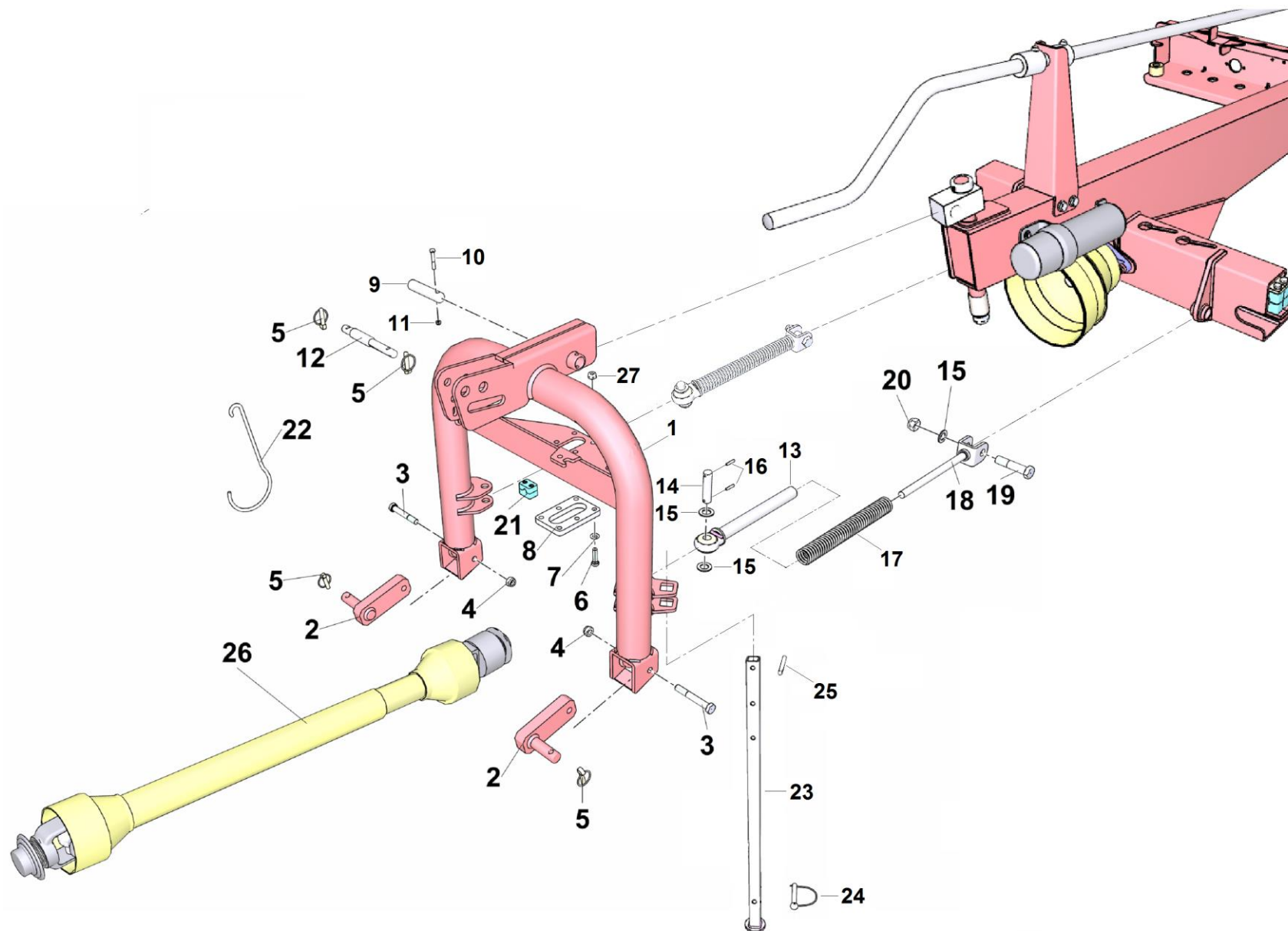



TABLE 1 - MOUNTED

Nr.	CODE	DESCRIPTION
1		THREE-POINT HITCH
2	18031422	PIN WITH BRACKET
3	3010408	H. H. SCREW M16X110 ZN
4	3020204	SELF LOCKING NUT M16
5	3080202	SAFETY PIN D.10
6	3011707	H. H. SCREW M12L45 10.9 ZN
7	3030162	WASHER M12 ZN
8	18032255	PLATE
9	18032256	HOLED PIN Ø28 L.135
10	3011210	H. H. SCREW M8X50
11	3020209	SELF LOCKING NUT M8
12	12310115	3-POINT PIN
13	18032259	CONNECTING ROD WITH BALL JOINT
14	18032362	PIN Ø22 L.89
15	3030176	WASHER M22 ZN
16	3080102	ELASTIC PIN 6X36
17	11010536	SPRING
18	18032258	CONNECTING ROD WITH BRACKET
19	18032363	SCREW
20	3020222	SELF LOCKING NUT M22
21	18033216	COLLAR C3
22	18032512	CARDAN HOOK
23	18032260	BEARING FOOT
24	3080204	SAFETY PIN D.10
25	3040117	ELASTIC PIN 8X80
26	8020443	CARDAN SHAFT 600 NM 2 NOTT.
27	3020202	SELF LOCKING NUT M12



TABLE 2 (1/2) - MOUNTED

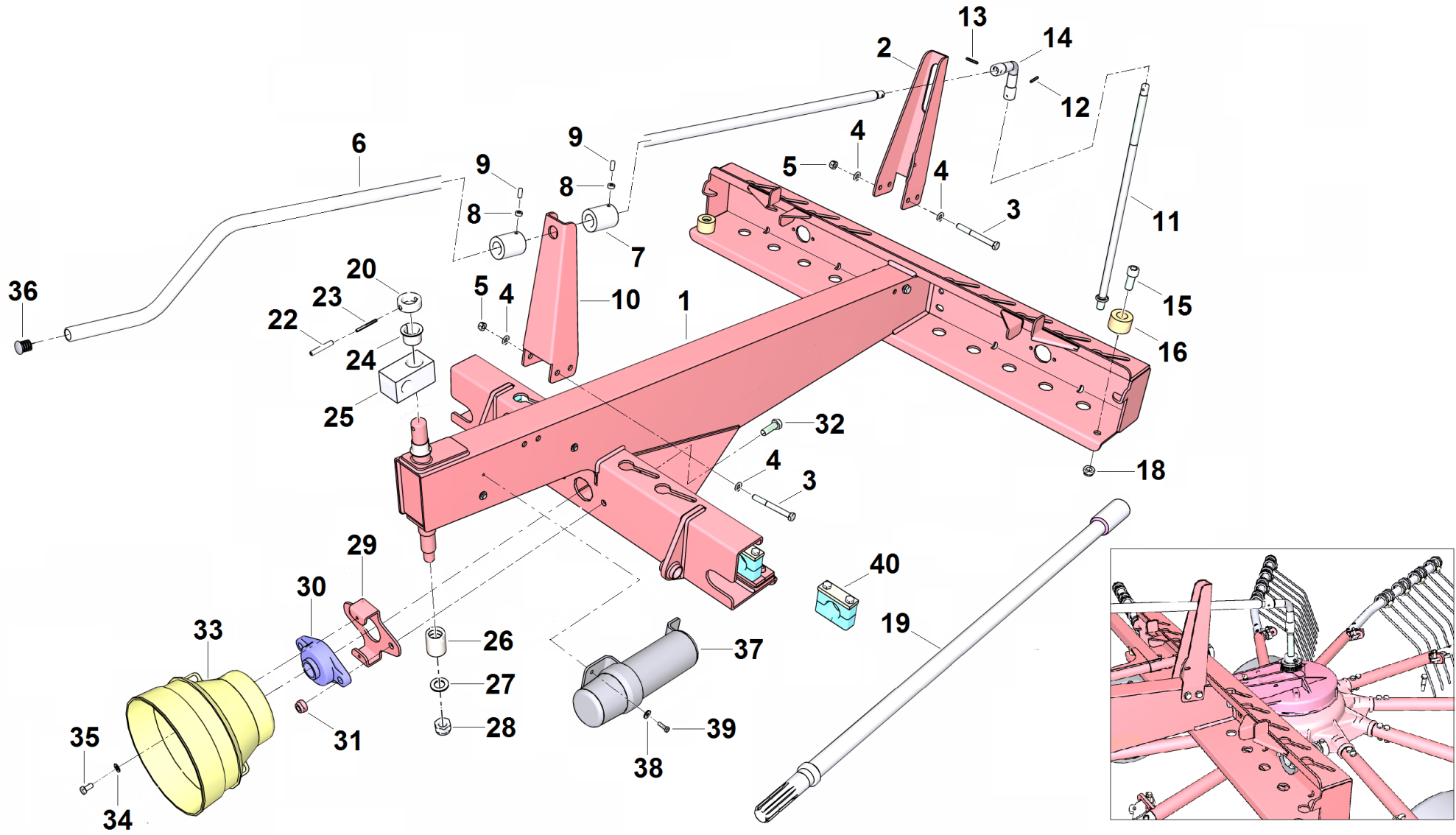



TABLE 2 (1/2) - MOUNTED

Nr.	CODE	DESCRIPTION
1	18032370	FRAME
2	18032263	REAR STRUT
3	3011313	H. H. SCREW M12X110 ZN
4	3030162	WASHER M12 ZN
5	3020202	SELF LOCKING NUT M12
6	18032261	AXLE
7	18032361	STOP
8	3020329	NUT M8 ZN
9	3050107	GRUB SCREW M8X20
10	18032267	FRONT STRUT
11	18032262	REGULATING SCREW
12	3080102	ELASTIC PIN 6X36
13	3080102	ELASTIC PIN 6X36
14	18033975	ARTICULED JOINT
15	3010660	H.S.H.C SCREW M16X40 ZN
16	18032232	SPRING
17	3020358	NUT M22X1,5 ZN
18	3020204	SELF LOCKING NUT M16
19	18032265	TRASSMISSION SHAFT
20	18032266	BUSH
21	12280006	SPACER PS 32X22X0,5
22	3080105	ELASTIC PIN 8X50
23	3080157	ELASTIC PIN 5X50
24	12240237	BUSH GLYCODUR 303426
25	18032257	SUPPORT
26	12071212	BUSH
27	3030176	WASHER M22 ZN
28	3020222	SELF LOCKING NUT M22
29	18033338	SUPPORT CAP
30	12250027	SUPPORT UCFL 207

TABLE 2 (2/2) - MOUNTED

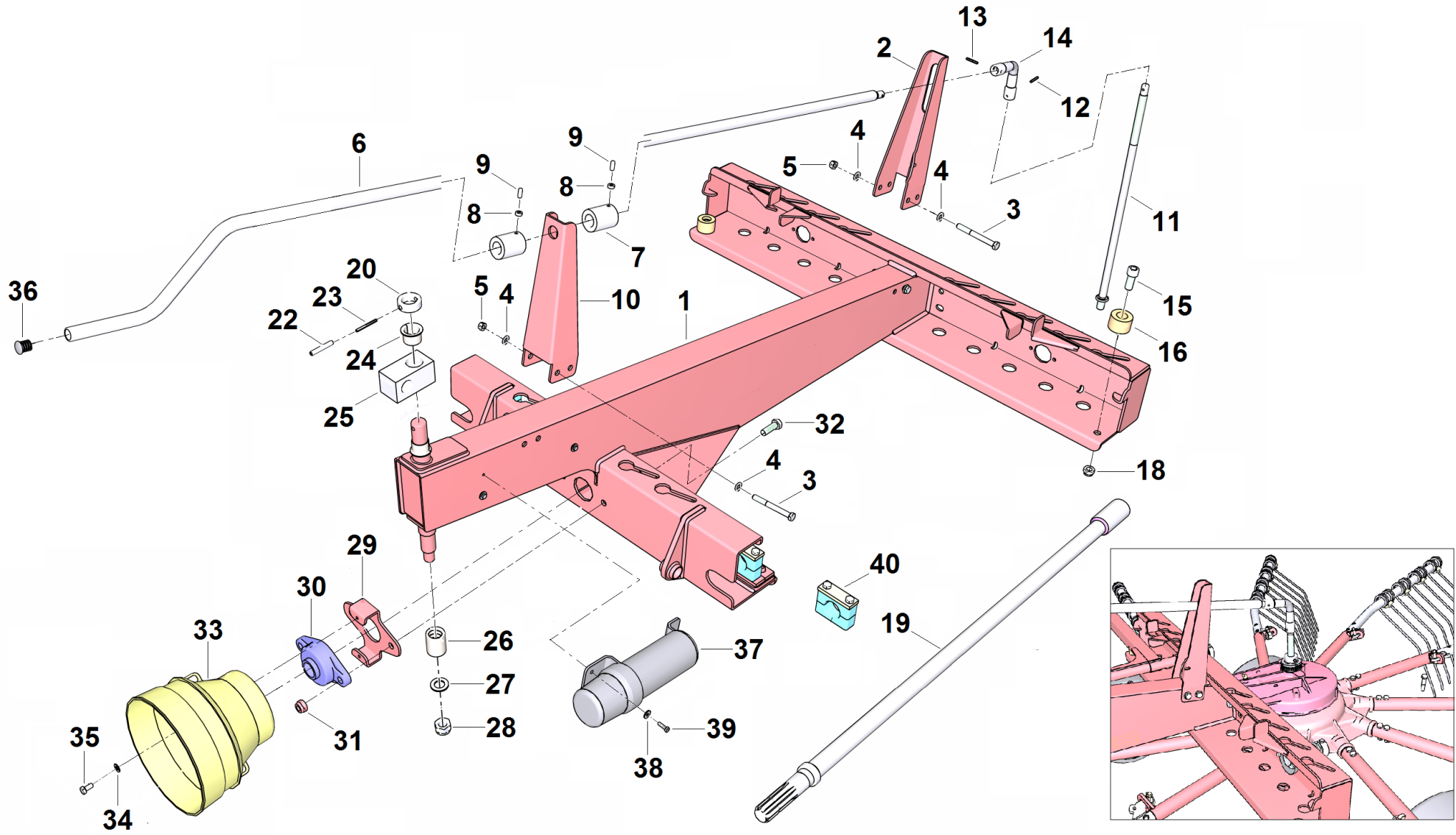



TABLE 3 - MOUNTED

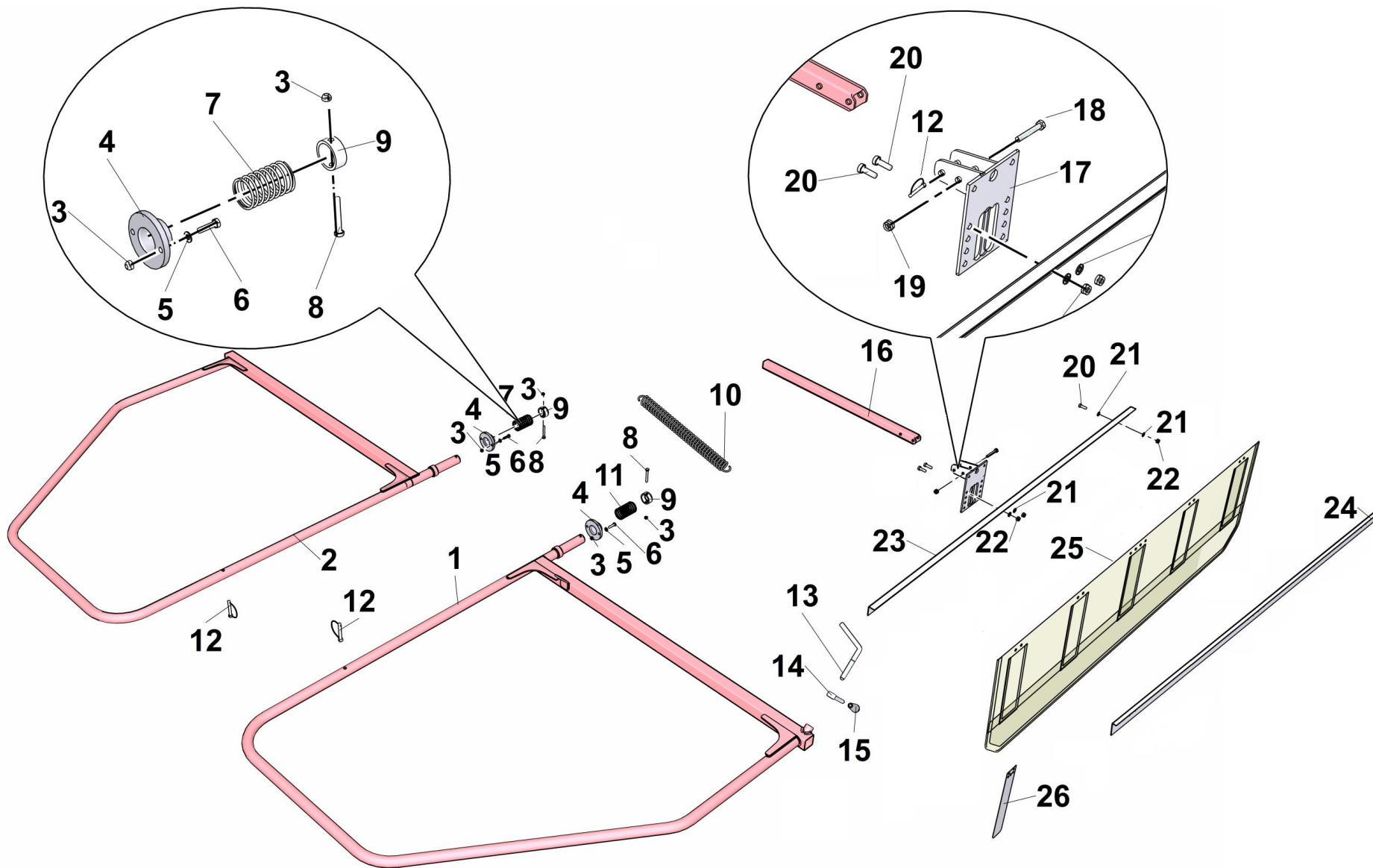





TABLE 3 - MOUNTED

Nr.	CODE	DESCRIPTION
1	18032273	LEFT PROTECTION
2	18032270	RIGHT PROTECTION
3	3020209	SELF LOCKING NUT M8
4	18032271	BUSH
5	3030156	WASHER M8 ZN
6	3010780	H. H. SCREW M8X30 ZN
7	11010537	SPRING
8	3011616	H. H. SCREW M8X60 ZN
9	18032286	SPRING STOP
10	11010534	SPRING
11	11010537	SPRING
12	3080204	SAFETY PIN D.10
13	18032285	LOCKING PIN
14	18033168	LOCKING RING NUT
15	3140001	KNOB
16	18032275	DEFLECTOR-HOLDER
17	18032366	DEFLECTOR-HOLDER BRACKET
18	3010756	H. H. SCREW M10X70 ZN
19	3020201	SELF LOCKING NUT M10
20	3011206	H. H. SCREW M10X30 ZN
21	3030159	WASHER M10 ZN
22	3020201	SELF LOCKING NUT M10
23	18032367	DEFLECTOR EXTERNAL FRAME
24	18032368	DEFLECTOR INTERNAL FRAME
25	12881029	DEFLECTOR
26	18032365	STIFFENING PLATE

TABLE 4 - MOUNTED

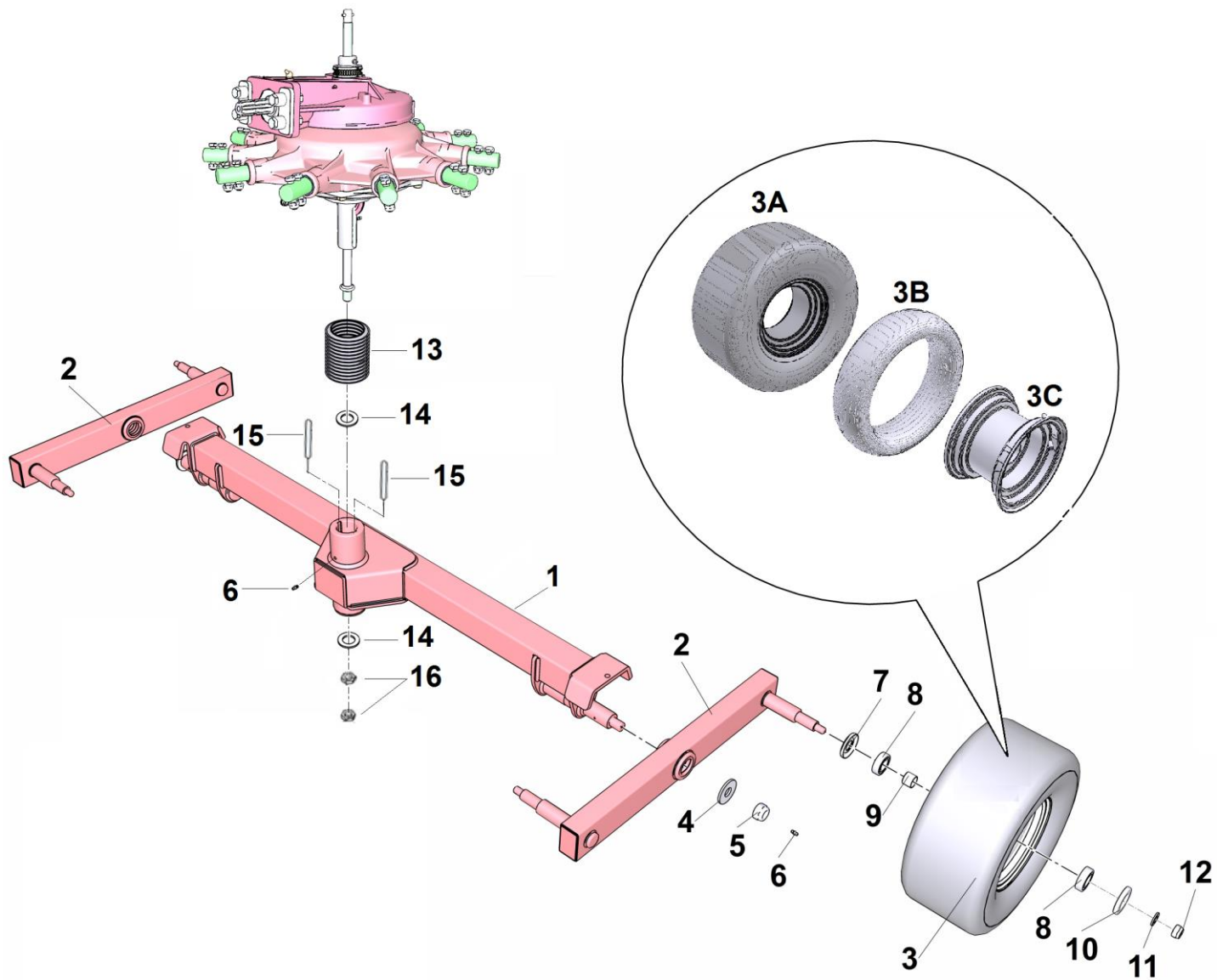



TABLE 5 - MOUNTED

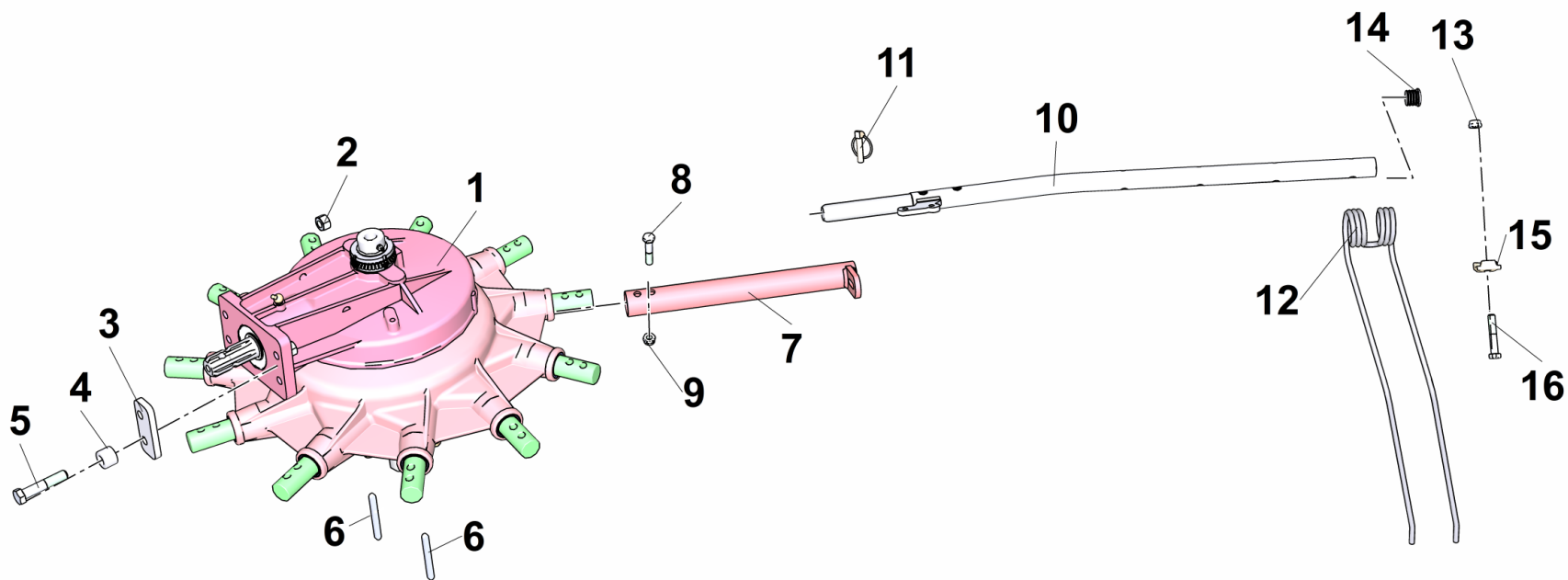



TABLE 6 (1/2) – PULL-TYPE

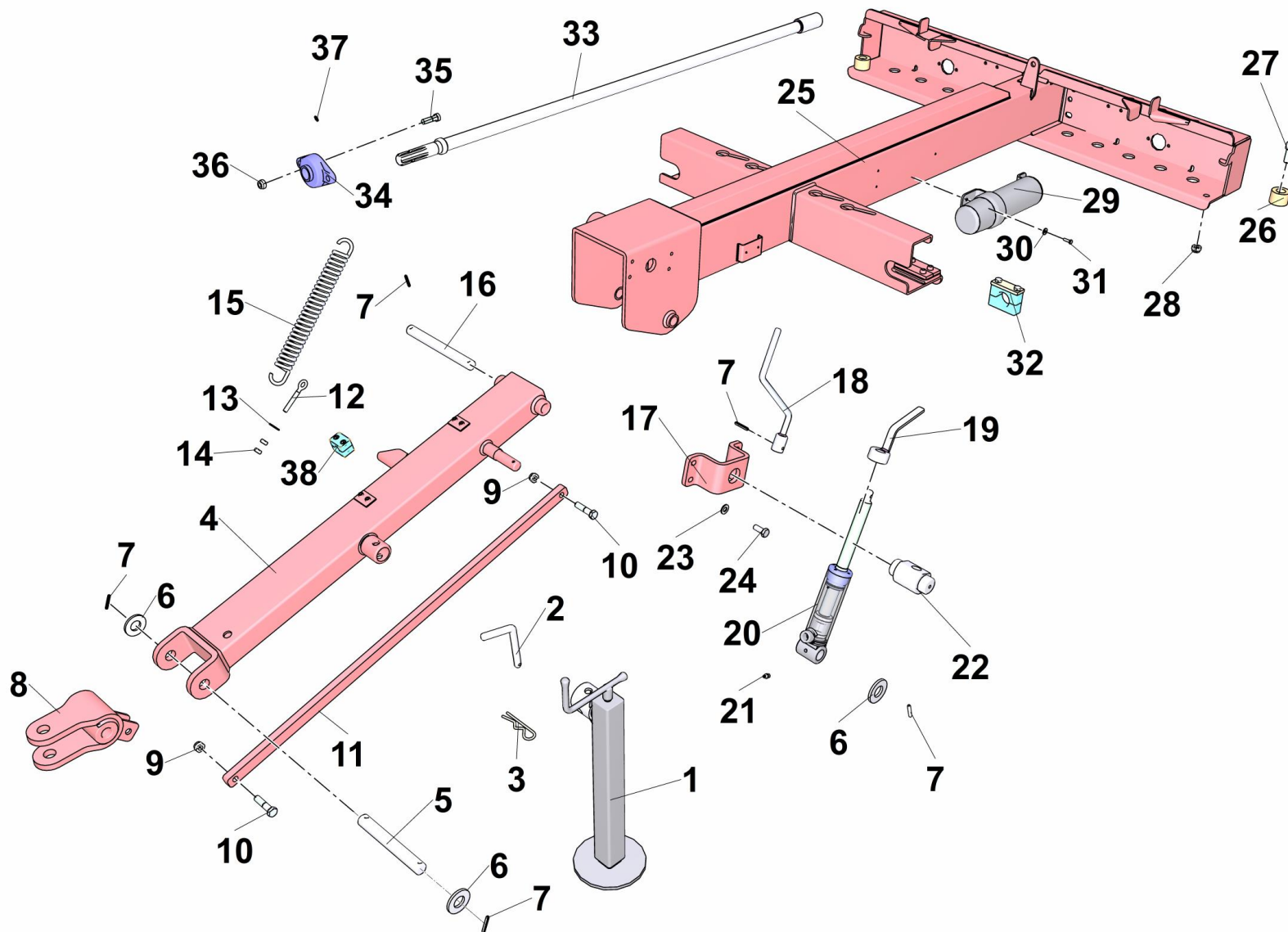





TABLE 6 (1/2) – PULL-TYPE

Nr.	CODE	DESCRIPTION
1	18032774	BEARING FOOT
2	18033195	HANDLE PIN
3	3040202	R COTTER PIN
4	18032229	PULL BAR
5	18032228	HOLED PIN
6	3030186	WASHER 56X26X5 ZN
7	3080102	ELASTIC PIN 6X36
8	18032227	COUPLING HITCH
9	3020203	SELF LOCKING NUT M14
10	3011202	H. H. SCREW M14X60 ZN
11	18032226	ROD
12	3220201	RING TENSIONER
13	3030169	WASHER M10 ZN
14	3020328	NUT M10 ZN
15	11010501	SPRING
16	18032238	HOLED PIN
17	18032235	CYLINDER BRACKET
18	18032233	REGULATING SCREW
19	18032234	RING
20	18032236	HYDRAULIC CYLINDER
21	3090101	GREASE ZERK M8X1
22	18032237	SPLIT NUT
23	3030159	WASHER M10 ZN
24	3011211	H. H. SCREW M10X25 ZN
25	18032231	FRAME
26	18032232	SPRING
27	3010660	H.S.H.C SCREW M16X40 ZN
28	3020204	SELF LOCKING NUT M16
29	9080022	MANUAL-HOLDER
30	3030160	WASHER M6 EXL ZN

TABLE 6 (2/2) – PULL-TYPE

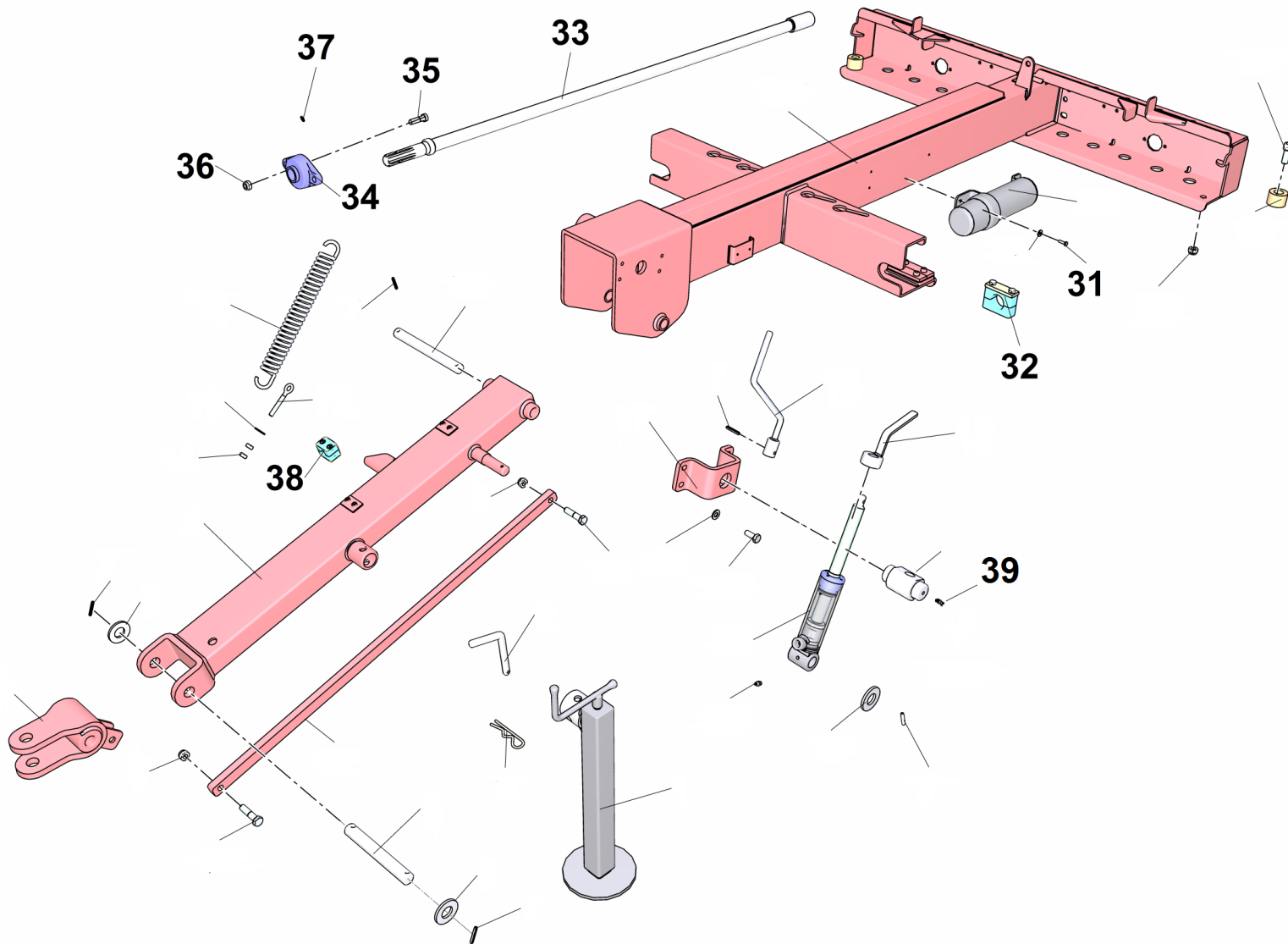



TABLE 7 (1/2) – PULL-TYPE

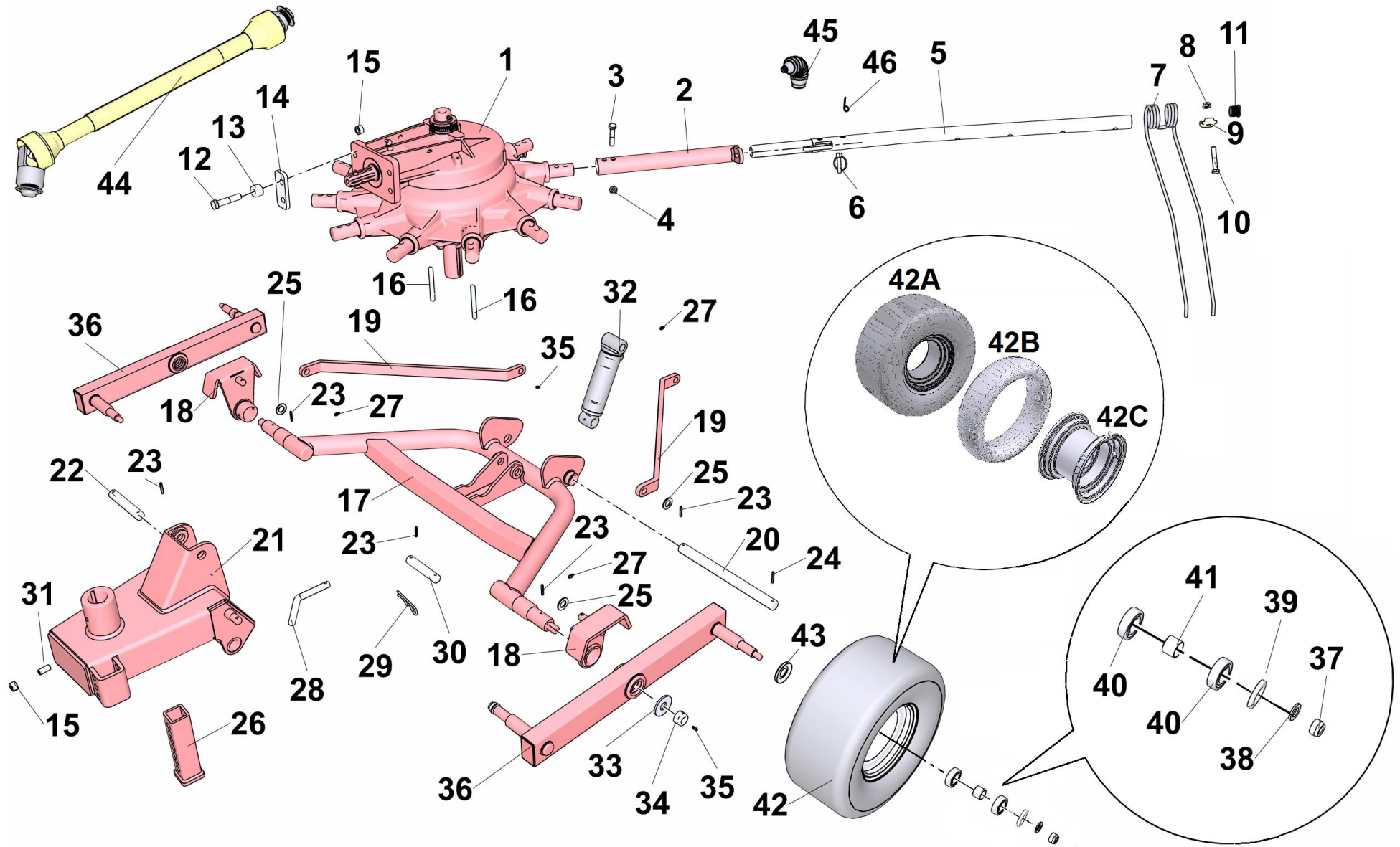



TABLE 7 (1/2) – PULL-TYPE

Nr.	CODE	DESCRIPTION
1	8010517	GEARBOX ROR -11
2	18032280	ARM-HOLDER
3	3011207	H. H. SCREW M12X60 ZN
4	3020202	SELF LOCKING NUT M12
5	18032279	ARM
6	3080202	SAFETY PIN D.10
7	18030584	SPRING
8	3020202	SELF LOCKING NUT M12
9	12881075	SPRING CLAMP
10	3011288	H. H. SCREW M12X70 ZN
11	9190013	RUBBER CAP D.35
12	3011631	H. H. SCREW M14X70 ZN
13	18033390	SPACER Ø28 L.20
14	18033315	PLATE FIX. ROTOR
15	3020363	NUT B. M14 ZN
16	3110029	TAB 10X8X110 A
17	18032360	TANDEM AXLE
18	18032240	TANDEM BLOCK
19	18032241	TANDEM ARM
20	18032247	HOLED PIN Ø30 L.370
21	18033308	GEARBOX SUPPORT
22	18032244	HOLED PIN Ø25 L.150
23	3080102	ELASTIC PIN 6X36
24	3080103	ELASTIC PIN 6X40
25	3030168	WASHER M20 ZN
26	18032242	STOP ROD
27	3090101	GREASE ZERK M8X1
28	18032284	HANDLE PIN Ø18
29	3040202	R COTTER PIN
30	18032283	HOLED PIN Ø25 L.130

TABLE 7 (2/2) – PULL-TYPE

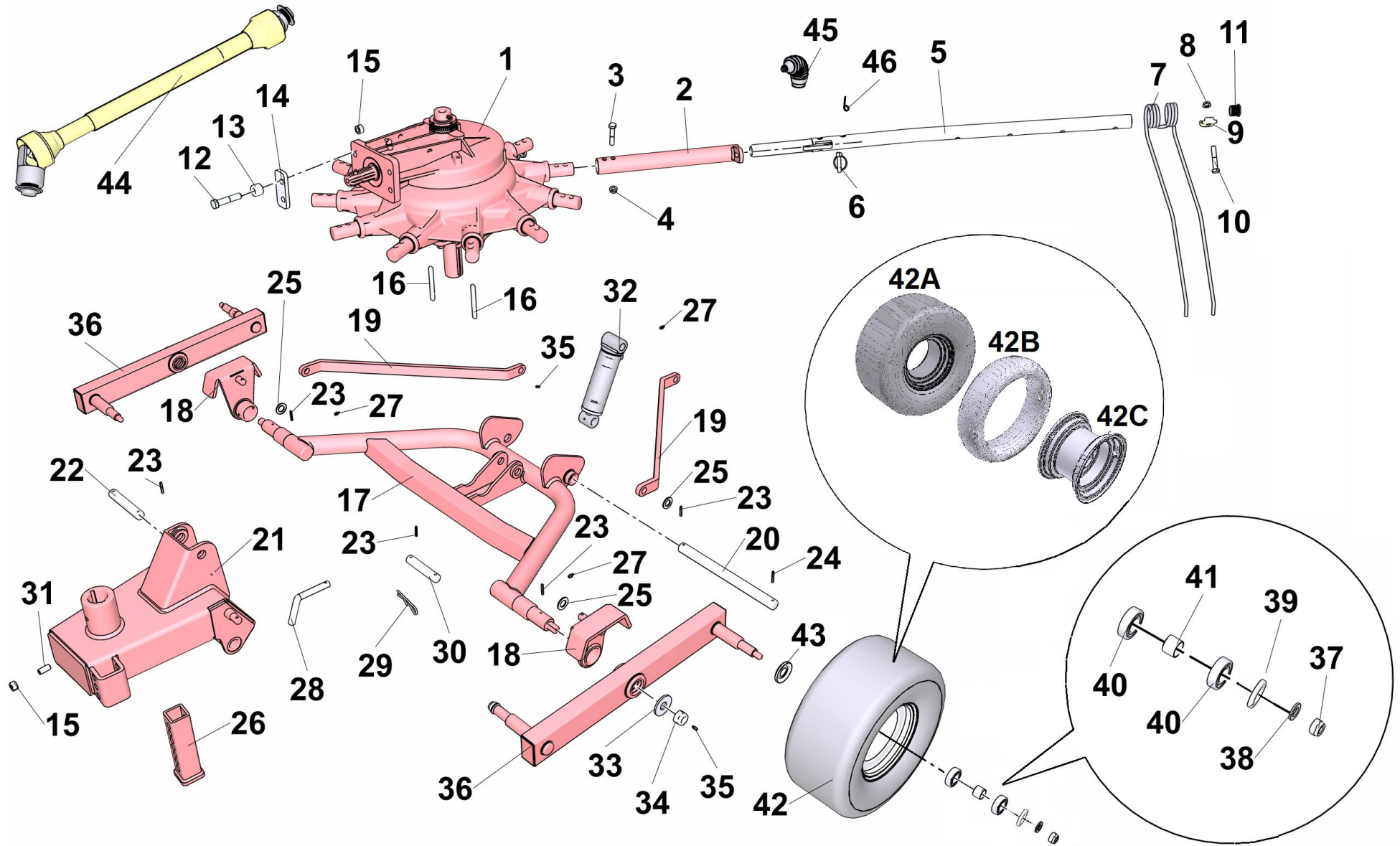





TABLE 8 – PULL-TYPE

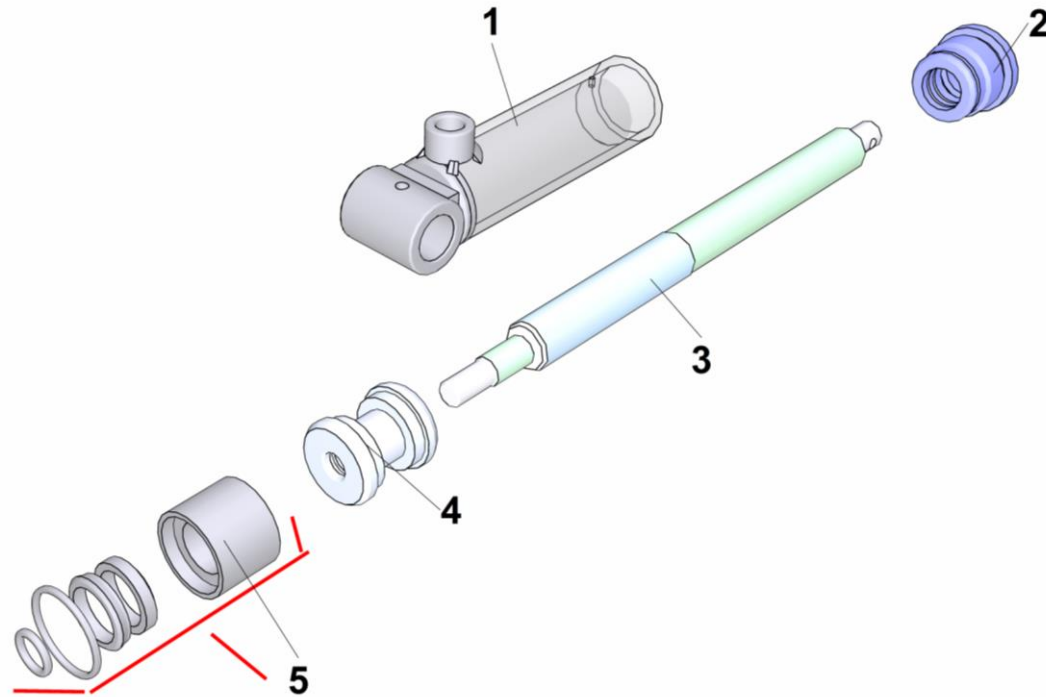

TABLE 8

Nr.	CODE	DESCRIPTION
1	18032236	COMPLETE CYLINDER Ø40 C.45
2		GUIDE
3		SHAFT
4		PISTON
5	18032253	SEAL KIT Ø40

TABLE 9 – PULL-TYPE

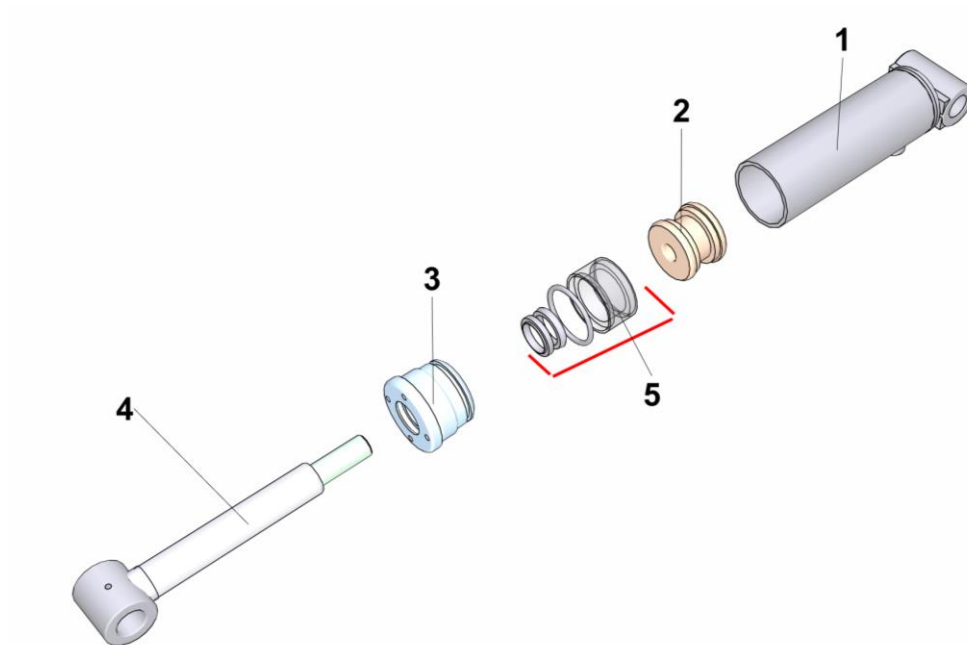

TABLE 9 – PULL-TYPE

Nr.	CODE		DESCRIPTION		
1	18032245		COMPLETE CYLINDER Ø60 C.107		
2			GUIDE		
3			SHAFT		
4			PISTON		
5	18032249		SEAL KIT Ø60		

TABLE 10 – PULL-TYPE

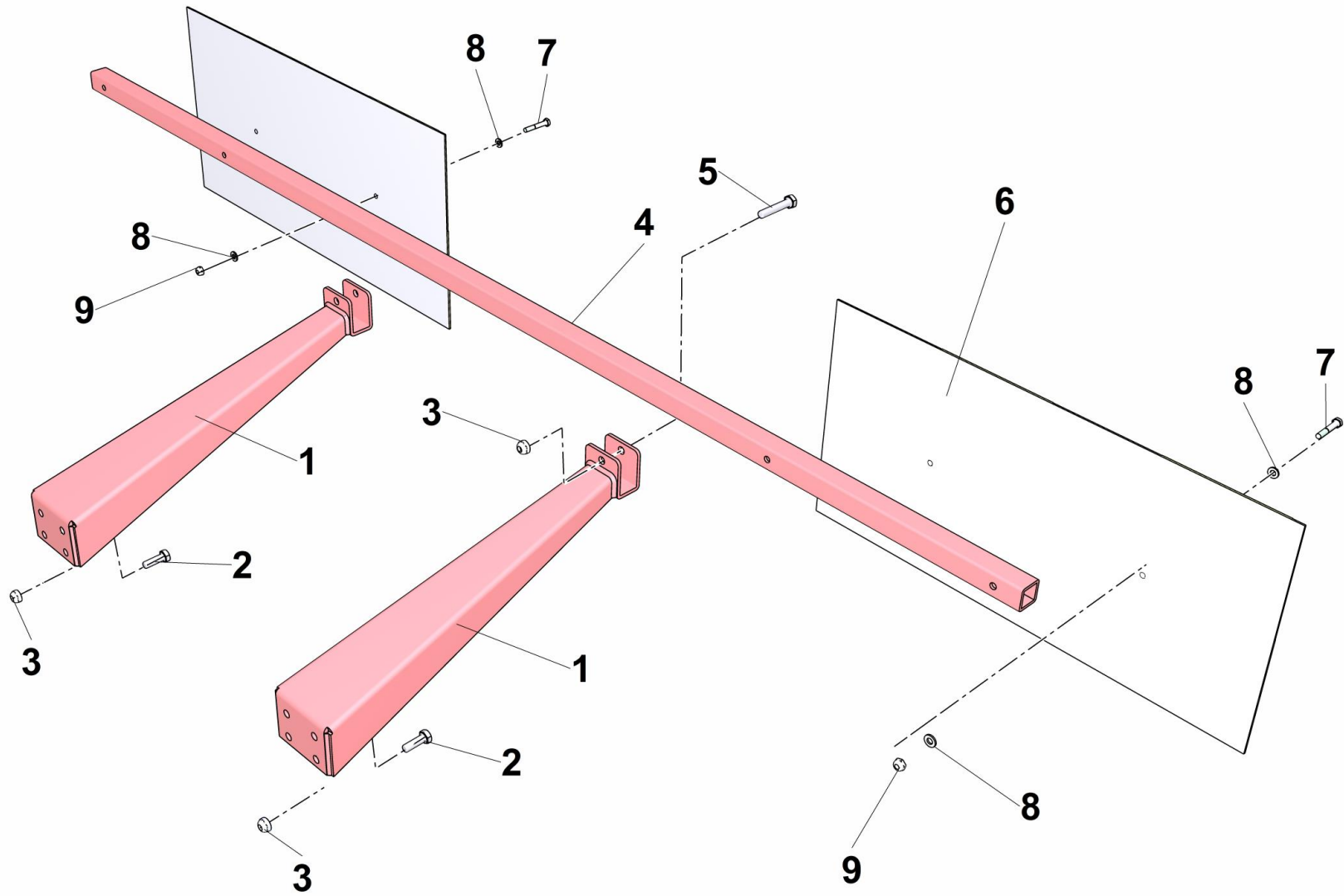



TABLE 11 – MOUNTED (OPTIONAL)

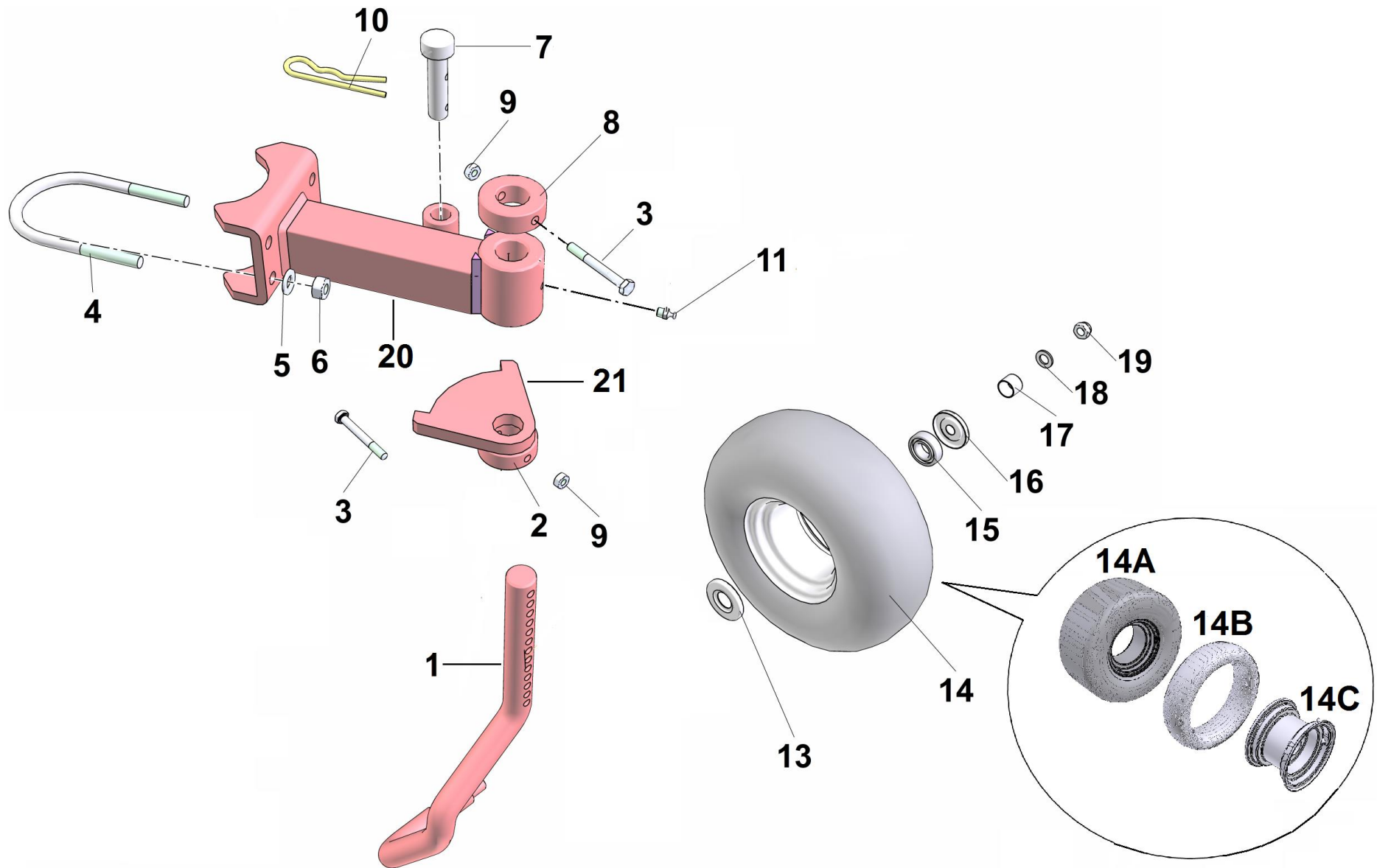





TABLE 11 – MOUNTED

Nr.	CODE	DESCRIPTION
1	18033035	WHEEL AXLE WITH VERTICAL SUPPORT
2	18033034	SECTOR
3	3011612	H. H. SCREW M8X70 ZN
4	3170119	U BOLT M12
5	3030162	WASHER M12 ZN
6	3020333	NUT M12 ZN
7	18032340	PIN
8	12070103	BUSH
9	3020329	NUT M8 ZN
10	3040202	R COTTER PIN
11	3090101	GREASE ZERK M8X1
12		
13	12070314	INTERNAL DUST COVER CAP
14	12170103	COMPLETE WHEEL 15.600.6
14A	12070313	TIRE 15.600.6
14B	12070312	AIR TUBE 15.600.6
14C	12070311	WHEEL RIM 15.600.6
15	12240313	BEARING 6205 2RS
16	12070315	EXTERNAL DUST COVER CAP
17	12070307	SPACER D.25
18	3030175	WASHER 30X17X3 ZN
19	3020204	SELF LOCKING NUT M16
20	18033033	ARM
21	18033034	SECTOR

TABLE 12 (1/2)

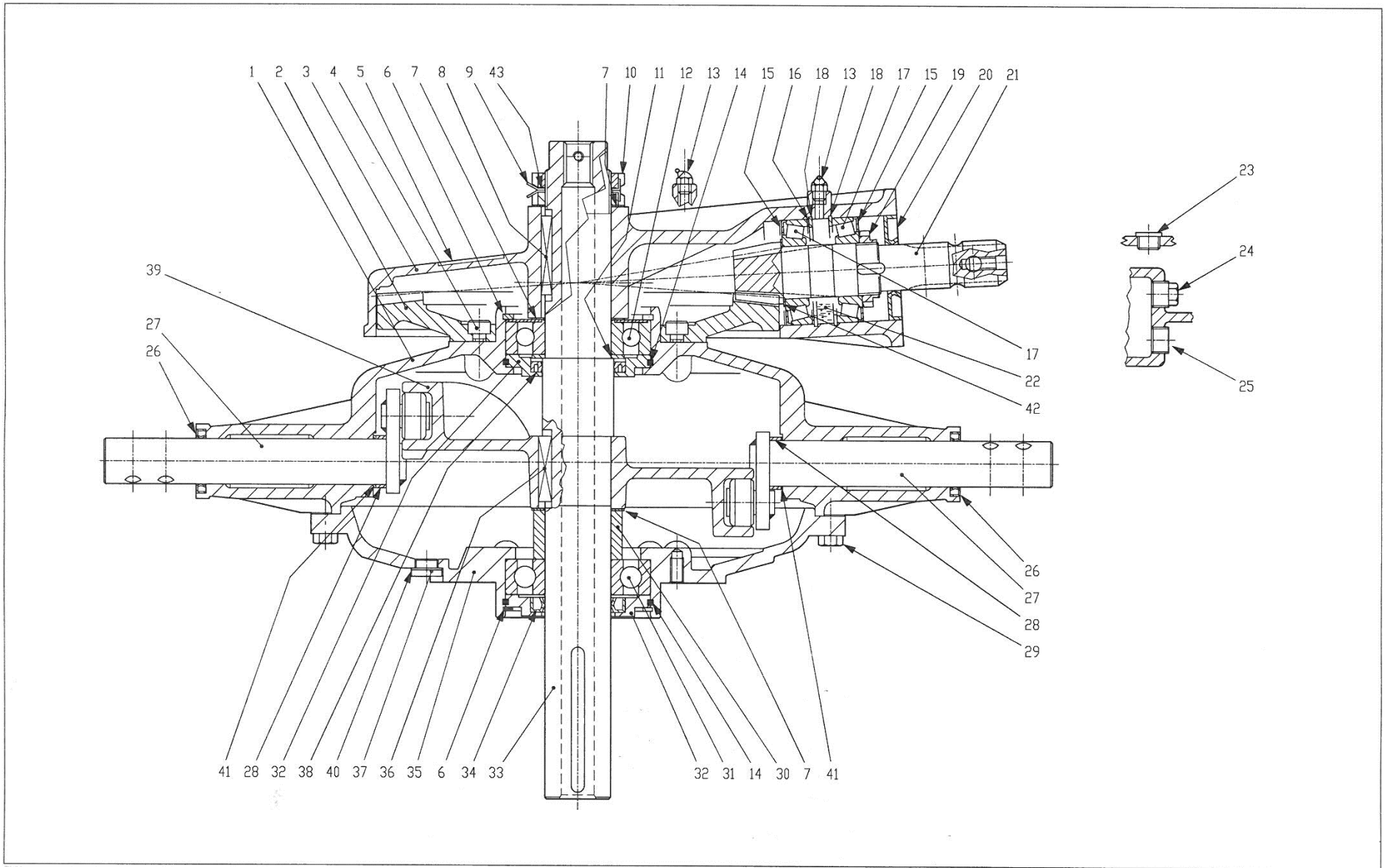



TABLE 12 (1/2)

Nr.	CODE	DESCRIPTION
1	18034017	MAIN BODY
2	18034018	CROWN Z82 M3,75
3	18034019	UPPER COVER
4	3010816	H.S.H.C SCREW 5931 M10X22
5	18034020	SERIAL PLATE
6	3120139	RING 110 UNI 7437
7	18034021	SHIM 50,3X70,3
8	3110028	KEI 10X8X60 UNI6604
9	3030187	WASHER 50X74X1,25
10	3180008	FASTENING GEAR M50X1,5
11	18034022	SHIM 70,2X50,2X2,5
12	12240256	BALL BEARING 6310 Z
13	3090111	GREASE NIPPLE 45G M10X1
14	18034023	SEAL 2-155
15	10011350	SEAL RING 30206 AV
16	18034024	SHIM 69X79,9
17	12240244	ROLLER BEARING 30208
18	3120147	RING 80 UNI 7437
19	18034025	NUT M40X1,5
20	12260097	RING 35X80X10
21	18034026	PINION Z10 M3.75
22	-	GREASE SHELL RETINAX WB2
23	18034027	HEX CAP 3/8" GAS
24	18034028	HEX CAP 1/2" GAS
25	18034029	HEX CAP 1/2" GAS
26	12260031	RING 35X45X7
27	18034030	ARM
28	18034035	BUSHING 35,3X43,5X9
29	3010281	SCREW 5739 M10X30
30	18034031	BUSHING 50,2X67X27,7

TABLE 12 (2/2)

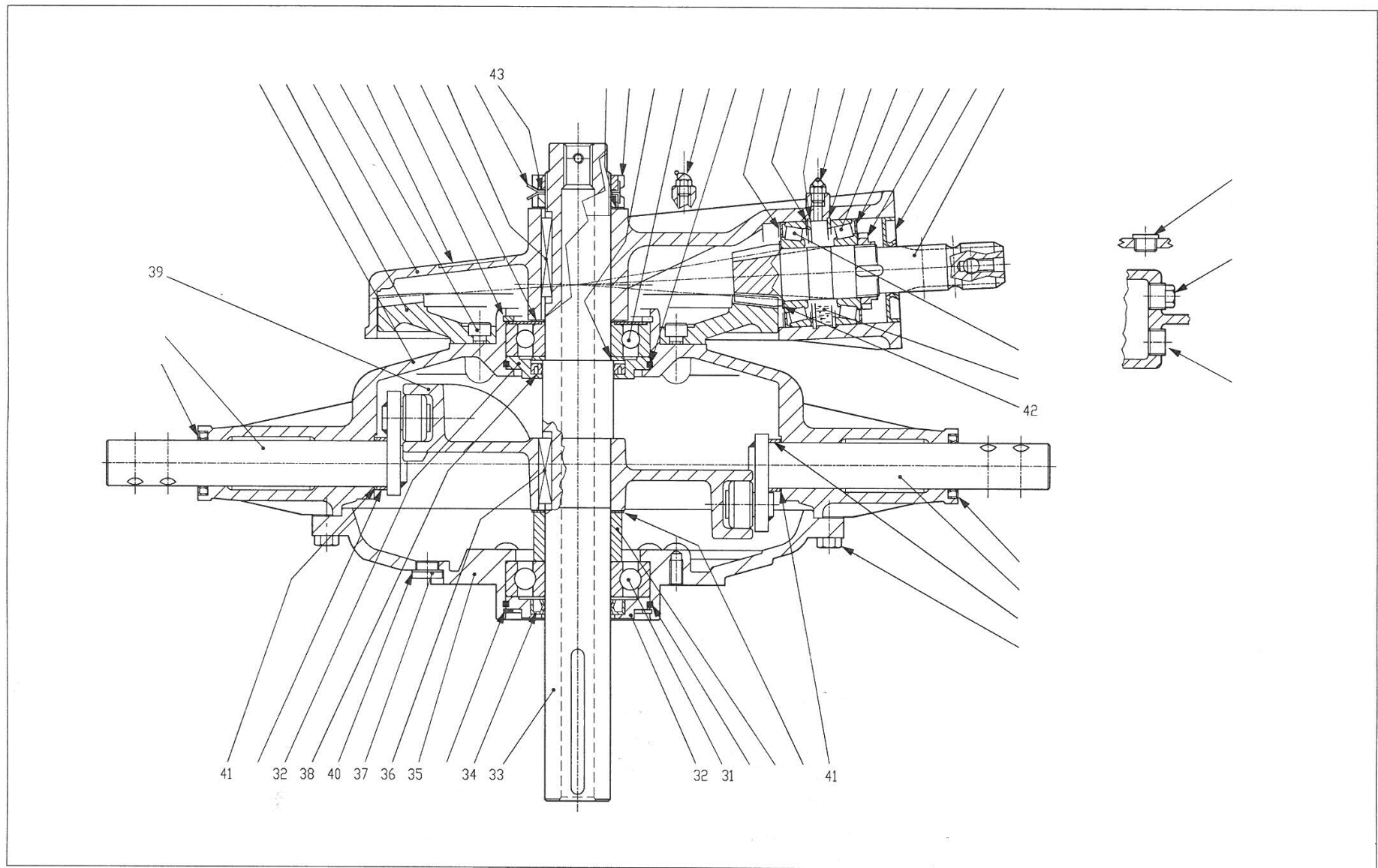



TABLE 13

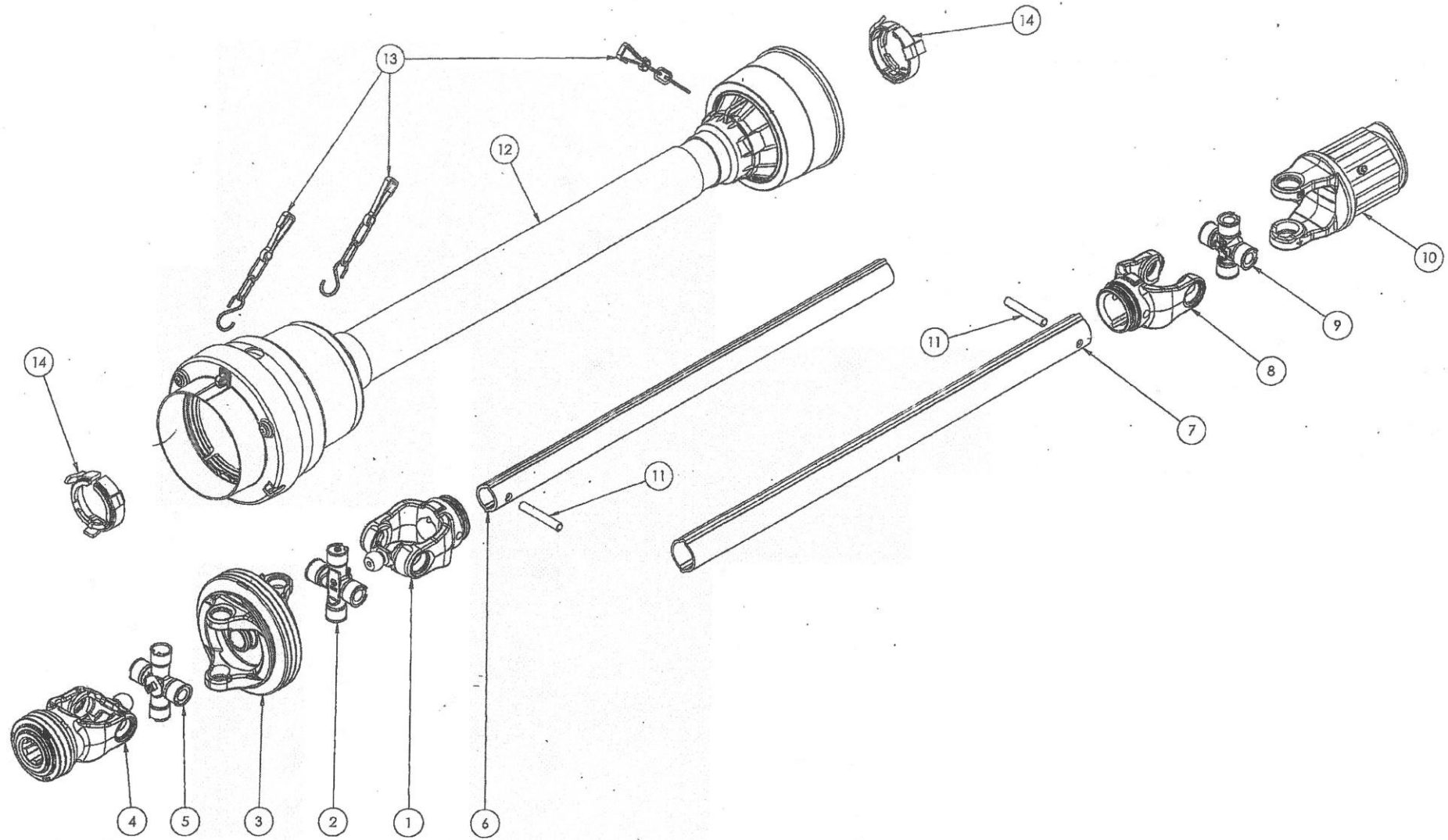





TABLE 14

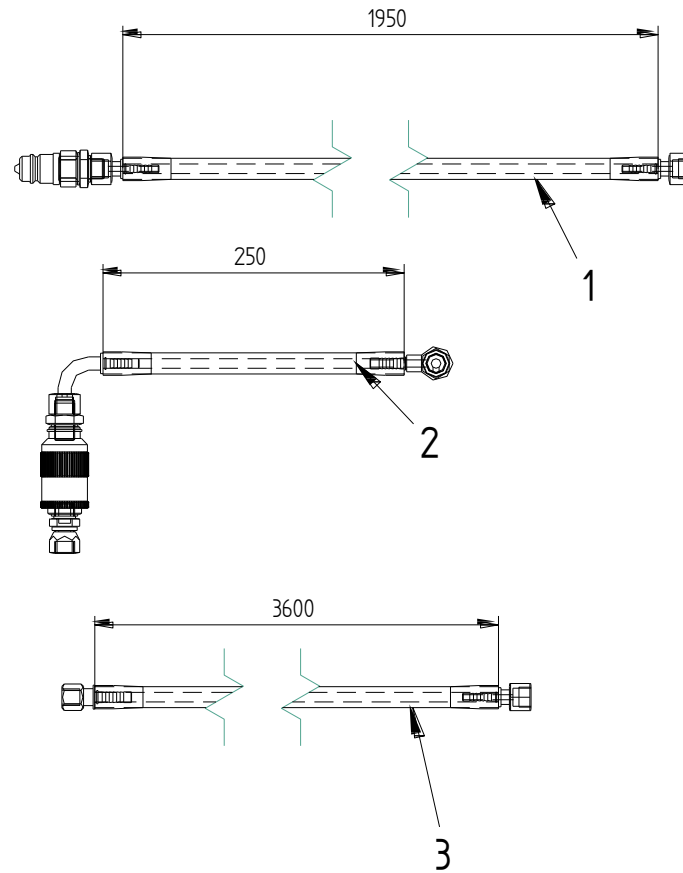

TABLE 14

Nr.	CODE	DESCRIPTION
1	12760606	HOSE IDRAULIC L.2000
2	12760607	HOSE IDRAULIC L.300
3	18032400	HOSE IDRAULIC L.3600

**TABLE 15**  
**Pittogrammi ed etichette - Safety labels and stickers - Étiquettes et stickers - Etiquetas de seguridad**



**TABLE 15**

Nr.	CODICE - CODE - CODE - CÓDIGO	DESCRIZIONE	DESCRIPTION	DESCRIPTION	DESCRIPCION	Q.ty
1	9270109					4
2	9270048					2
3	9270164					1
4	9270043					2
10	9270075					..
11		KIT (1 + 2 + 3 + 4)				



## Spare parts form

When ordering spare parts please make photo stats of this order form, fill out and mail or fax it directly to us at this address:

### H&S

2608 S. Hume Avenue  
P.O. Box 768 • Telephone (715) 387-3414  
FAX (715) 384-5463 • Website [www.hsmfgco.com](http://www.hsmfgco.com)  
Marshfield, WI 54449

To ensure prompt assistance and replacement of parts always supply below required information, thank you.

company name			
Invoice address			
Country			
Destination of goods If different from above			
Pos.	Code number	Description	Quantity

Rev./Issue Rev./Rev.	Modifica / Change / Changement / Modificación	Pagine / Pages Pages / Páginas	Data / Date Date / Fecha
4	Esploso ruote (tav.4, 7 e 11)	68, 69, 76, 77, 78, 79, 84, 85	1/2016
4a	SP: changed code of item 8 table 13	91	2/2016
5	SP: improvement of tables 1 and 2 (graphic part) – tav.4: added items 14, 15 and 16	60, 62, 64, 68 and 69	11/2016
5a	AI: tav16 added item 7 SP: tav.7 changed code of item 44	43 and 79	2/2017
5b	UM: changed safety pictograms SP: added table 15	13,14 and 93	5/2017



2608 S. Hume Avenue  
P.O. Box 768 • Telephone (715) 387-3414  
FAX (715) 384-5463 • Website [www.hsmfgco.com](http://www.hsmfgco.com)  
Marshfield, WI 54449